

La Redoute

♦ INTERIEURS ♦

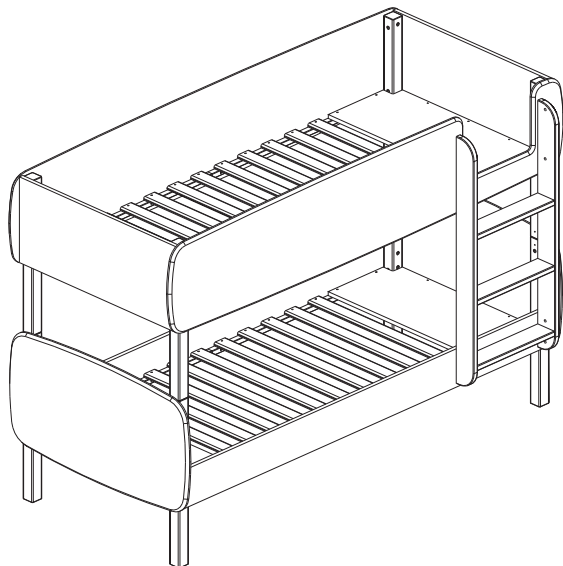

Option 1

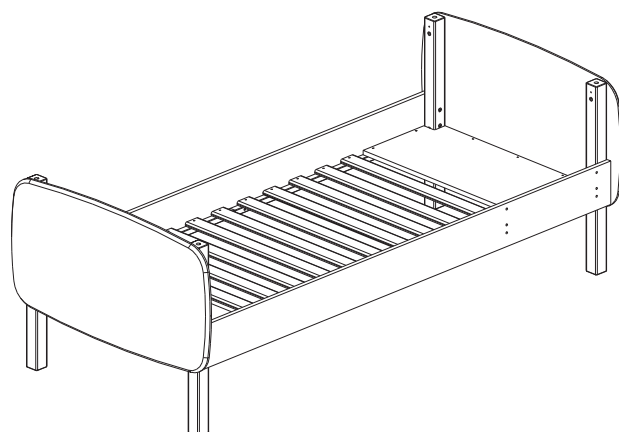

Option 2

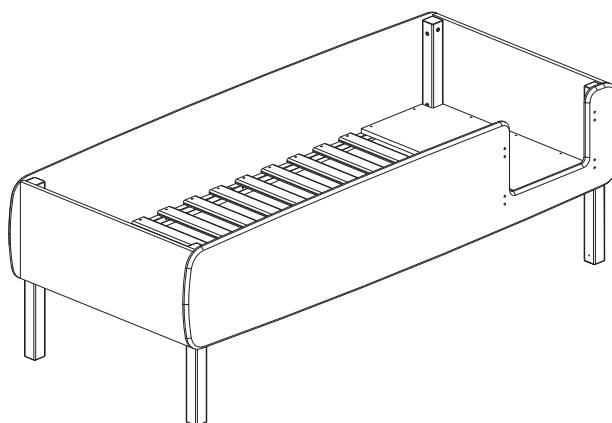

ÉLEVÉ - HIGHT
SCHWIERIG - DIFÍCIL

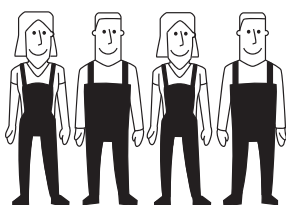

4

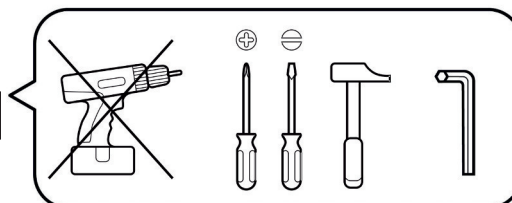

FR / Si vous avez des questions sur votre produit, email: sitegsm@redoute.fr ou appeler au: 0 969 323 515.

UK / If you need information about your product, email: helpline@redoute.co.uk or call: 033 0303 0199.

CH / Wenn Sie Fragen zu Ihrem Produkt, email: info@redoute.ch oder anrufen: FR/IT: 0848 848 505, DE: 0848 848 505.

BE / Si vous avez des questions sur votre produit, email: serviceclient@redoute.be ou appeler: 056 85 15 15 - Als u vragen over uw product, email: klantendienst@redoute.be of bel: 056 85 15 00.

ES / Si tiene alguna pregunta acerca de su producto, email: contacto@laredoute.es o llamar: 90233 0033.

PT / Se você tiver dúvidas sobre o seu produto, email: contacto@redoute.pt ou chamar: 707 2010 10.

SE / Om du har frågor om din produkt, email: service@laredoute.se eller ring: 033 - 48 20 00.

NW / Hvis du trenger informasjon om produktet, email: service@laredoute.no eller telefon: 66-89-15-00.

IT / Se hai delle domande sul tuo articolo, ecco la mail via nuestro website.

PL / Jeśli mają Państwo pytania dotyczące produktu, prosimy pisać na numer telefonu: 32 225 28 28.

RU / Если Вам необходима дополнительная информация о товаре, свяжитесь с нами по телефонам 8 800 555 75 35 / 8 (495) 795 30 30, email: info@laredoute.ru.

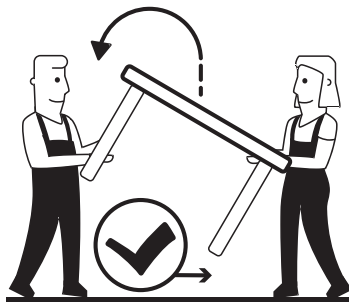
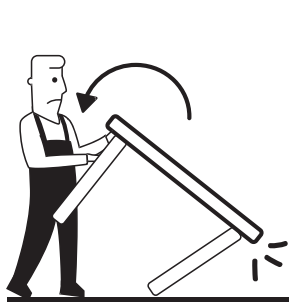
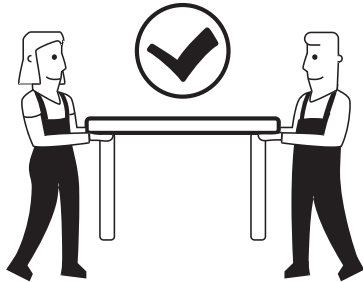
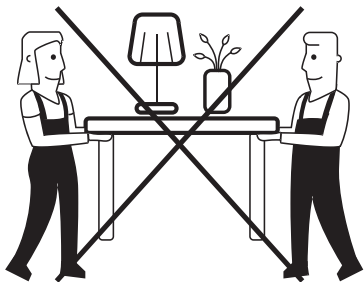
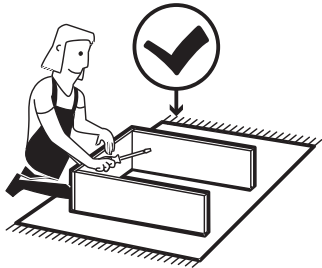
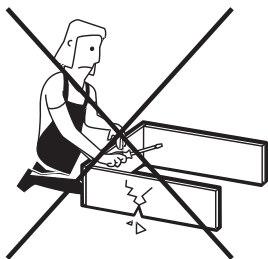

FR / IMPORTANT – LIRE ATTENTIVEMENT – À CONSERVER POUR RÉFÉRENCE ULTÉRIEURE

- a) AVERTISSEMENT Les lits surélevés et le lit supérieur des lits superposés ne conviennent pas pour les enfants de moins de six ans en raison du risque de blessures liées à des chutes.
- b) AVERTISSEMENT S'ils ne sont pas utilisés correctement, les lits superposés et les lits surélevés peuvent présenter un sérieux risque de blessure par étranglement. Ne jamais attacher ou suspendre des éléments à des parties du lit superposé qui ne sont pas destinés à être utilisés avec ledit lit. Ces éléments comprennent, sans toutefois s'y limiter, les cordes, les ficelles, les cordons, les crochets, les ceintures et les sacs.
- c) AVERTISSEMENT Les enfants peuvent se retrouver coincés entre le lit et un mur, une partie d'un toit incliné, le plafond, des meubles adjacents (par exemple, des placards) ou autre. Pour éviter tout risque de blessure grave, la distance entre la barrière de sécurité supérieure et les éléments environnants ne doit pas dépasser 75 mm ou doit être supérieure à 230 mm.
- d) AVERTISSEMENT Ne pas utiliser le lit superposé ou le lit surélevé si une pièce de la structure est manquante ou cassée.
- e) Veillez à toujours suivre les instructions du fabricant.
- f) La taille recommandée du matelas à utiliser avec le lit est de 190 x 90 cm.
- g) Il est nécessaire de ventiler la pièce afin de maintenir un niveau peu élevé d'humidité et d'empêcher le développement de moisissure dans le lit et autour de celui-ci.
- j) L'épaisseur maximale du matelas à utiliser doit être de 18 cm.
- k) Vérifier régulièrement que tous les éléments de fixation sont correctement serrés.
- l) Conforme aux exigences de sécurité de la norme NF EN 747+A1 : 2015.

UK / IMPORTANT – READ CAREFULLY – RETAIN FOR FUTURE REFERENCE

- a) WARNING High beds and the upper bed of bunk beds are not suitable for children under six years due to the risk of injury from falls
- b) WARNING Bunk beds and high beds can present a serious risk of injury from strangulation if not used correctly. Never attach or hang items to any part of the bunk bed that are not designed to be used with the bed, for example, but not limited to ropes, strings, cords, hooks, belts and bags
- c) WARNING Children can become trapped between the bed and the wall, a roof pitch, the ceiling, adjoining pieces of furniture (e.g. cupboards) and the like. To avoid risk of serious injury the distance between the top safety barrier and the adjoining structure shall not exceed 75 mm or shall be more than 230 mm
- d) WARNING Do not use the bunk bed/high bed if any structural part is broken or missing.
- e) Always follow the manufacturer's instructions.
- f) Recommended size of the mattress(es) is 190 x 90 cm.
- g) Ventilation of the room is necessary in order to keep the humidity low and to prevent mould in and around the bed.
- j) The maximum thickness of the mattress is 18 cm.
- k) Check regularly that all assembly fastenings are properly tightened.
- l) Compliant with the standard NF EN 747+A1 : 2015.

DE / WICHTIG - AUFMERKSAM LESEN - ZUR SPÄTEREN EINSICHTNAHME AUFZUBEWAHREN

- a) WARNUNG Hochbetten und das obere Bett bei Etagenbetten sind wegen des Verletzungsrisikos durch Stürze nicht für Kinder unter sechs Jahren geeignet.
- b) WARNUNG Wenn sie nicht richtig verwendet werden, können Hochbetten und Etagenbetten ein schweres Verletzungsrisiko durch Strangulierung darstellen. Es dürfen niemals Elemente an Teilen des Hochbetts befestigt oder aufgehängt werden, die nicht zur Verwendung mit besagtem Bett bestimmt sind. Diese Elemente umfassen, sind aber nicht beschränkt auf, Seile, Fäden, Schnüre, Haken, Gürtel und Taschen.
- c) WARNUNG Kinder können sich zwischen dem Bett und einer Wand, einer gekippten Wandstelle, der Decke, Möbeln in der Nähe (zum Beispiel Schranke) oder anderem einklemmen. Um jedes Risiko einer schweren Verletzung zu vermeiden, darf der Abstand zwischen der oberen Sicherheitsschranke und den Elementen in der Umgebung 75 mm nicht überschreiten oder muss größer als 230 mm sein.
- d) WARNUNG Das Hochbett oder das Etagenbett darf nicht verwendet werden, wenn ein Teil des Aufbaus fehlt oder beschädigt ist. Ersatzteile müssen beim Hersteller oder im Laden bestellt werden.
- e) Die Montage- und Gebrauchsanweisungen des Herstellers müssen unbedingt immer befolgt werden.
- f) Die empfohlene Größe der mit dem Bett zu verwendenden Matratze beträgt 190 x 90 cm. Höchstdicke der Matratze: 18 cm.

- g) Es ist notwendig, den Raum zu lüften, um einen geringen Feuchtigkeitsgrad aufrechtzuerhalten und die Entwicklung von Schimmel im Bett und seiner Umgebung zu verhindern.
- k) Die Montagevorrichtungen müssen immer angemessen festgezogen und regelmäßig überprüft werden. Wenn nötig, erneut festziehen.
- l) Entspricht den europäischen Sicherheitsanforderungen der Norm NF EN 747+A1 : 2015.
- m) Wenn ein Nachtlicht vorhanden ist, kann dies dem im oberen Bett schlafenden Kind mehr Sicherheit geben.

NL / BELANGRIJK - AANDACHTIG LEZEN - TE BEWAREN VOOR LATERE RAADPLEGING

- a) WAARSCHUWING De verhoogde bedden en het hoge bed van stapelbedden zijn niet geschikt voor kinderen jongeren dan zes omwille van het gevaar op kwetsuren door valpartijen,
- b) WAARSCHUWING Wanneer ze niet correct gebruikt worden, kunnen verhoogde bedden en stapelbedden een ernstig gevaar inhouden op kwetsuren door wurging. Nooit dingen bevestigen of ophangen aan delen van het stapelbed die niet bestemd zijn voor gebruik met het desbetreffende bed. Deze elementen omvatten, zonder hiertoe beperkt te zijn, koorden, touwen, snoeren, haken, riemen en zakken of tassen,
- c) WAARSCHUWING Kinderen kunnen vast komen te zitten tussen het bed en een muur, een deel van het hellend dak, het plafond, naburige meubels (bijvoorbeeld kasten) of andere zaken. Om elk gevaar op een ernstige kwetsuur te vermijden, mag de afstand tussen de bovenste veiligheidsstang en de omliggende elementen niet groter zijn dan 75 mm of moet deze groter zijn dan 230 mm,
- d) WAARSCHUWING Het verhoogde bed of stapelbed niet gebruiken wanneer een onderdeel van de structuur ontbreekt of defect is. De vervangstukken moeten bij de fabrikant of winkel besteld worden.
- e) U moet steeds de montage- en gebruikrichtlijnen van de fabrikant volgen,
- f) De aanbevolen afmeting van de bij het bed te gebruiken matras is 190 x 90 cm. Maximale dikte van de matras: 18 cm,
- g) U moet de ruimte goed verluchten om de vochtigheidsgraad te beperken en schimmelvorming in het bed en zijn omgeving te vermijden,
- k) De assemblageonderdelen moeten steeds goed vastgezet zijn en regelmatig gecontroleerd worden. Deze indien nodig aanspannen.
- l) Conform de Europese veiligheidsnormen van de norm NF EN 747+A1: 2015.
- m) Een nachtlampje kan het kind in het bovenste bed meer veiligheid bieden

PT / IMPORTANTE - LER ATENTAMENTE - A GUARDAR PARA REFERÊNCIA FUTURA

- a) AVISO As camas sobre-elevadas e a cama superior dos beliches não são adaptadas para as crianças menores de seis anos devido ao risco de ferimentos ligados a quedas,
- b) AVISO Se não forem utilizados corretamente, os beliches e as camas sobre-elevadas podem apresentar um sério risco de ferimento por estrangulamento. Nunca amarrar ou suspender elementos em partes do beliche que não estão destinadas para ser utilizados com a dita cama. Estes elementos incluem, não sendo esta lista exaustiva, as cordas, os fios, os cordões, os ganchos, os cintos e os sacos,
- c) AVISO As crianças podem ficar bloqueadas entre a cama e uma parede, uma parte de um telhado inclinado, o teto, móveis adjacentes (por exemplo, armários) ou outro. Para evitar qualquer risco de ferimento grave, a distância entre a barreira de segurança superior e os elementos circundantes não deve ultrapassar 75 mm ou deve ser superior a 230 mm,
- d) AVISO Não utilizar o beliche ou a cama sobre-elevada se faltar uma peça da estrutura ou se uma peça estiver partida. As peças sobressalentes devem ser pedidas ao fabricante ou à loja.
- e) É obrigatório seguir sempre as instruções de montagem e de utilização do fabricante
- f) O tamanho recomendado do colchão a utilizar com a cama é de 190 x 90 cm, Espessura do colchão máximo: 18 cm.
- g) É necessário ventilar a peça de forma a manter um nível mais elevado de humidade e de impedir o desenvolvimento de bolor na cama e na sua periferia
- k) Os dispositivos de montagem devem estar sempre apertados e regularmente verificados. Aperta-los se necessário.
- l) Conforme às exigências europeias de segurança da norma NF EN 747+A1 : 2015.
- m) A presença de uma luz de presença pode dar mais segurança à criança que estiver a dormir na cama de cima

ES / IMPORTANTE - LEER CON ATENCION -CONSERVAR PARA FUTURAS REFERENCIAS

- ADVERTENCIA Las camas elevadas y la cama superior de las literas no son convenientes para niños menores de seis años debido al riesgo de lesiones por caída.
- ADVERTENCIA Si no se emplean correctamente, las camas elevadas y las literas podrían presentar riesgo de lesiones por estrangulación. No enganche o suspenda elementos a las partes de la litera que no estén destinadas a emplearse con la cama. Estos elementos pueden ser, sin que por ello la lista sea limitativa, cuerdas, cintas, cordones, ganchos, cinturones y bolsas.
- ADVERTENCIA Los niños podrían quedar atrapados entre la cama y la pared, una parte del techo inclinada, el techo, muebles adyacentes (armarios por ejemplo) u otros. Para evitar cualquier riesgo de lesión grave, la distancia entre la barrera de seguridad superior y los elementos que la rodean no deben superar los 75 mm o ser superiores a 230 mm.
- ADVERTENCIA No utilice una litera o cama elevada si una pieza de la estructura falta o está dañada. Las piezas de recambio deben solicitarse al fabricante o a la tienda.
- Siempre será obligatorio seguir las instrucciones de montaje y empleo del fabricante.
- El tamaño del colchón recomendado para la cama es de 190 x 90 cm, Espesor máximo del colchón: 18 cm.
- También será necesario ventilar la habitación para mantener un nivel de humedad poco elevado y evitar el desarrollo de mohos en la cama y su entorno.
- Los dispositivos de ensamblaje deben apretarse de manera adecuada y comprobarse regularmente. Apretarlos si fuera necesario.
- Cumple los requisitos europeos de seguridad de la norma NF EN 747+A1: 2015.
- una luz de noche ofrecerá más seguridad al niño que duerme en la cama superior.

SE / VIKTIGT – BÖR LÄSAS NOGA - SPARA FÖR SENARE BRUK

- WARNING: Upphöjda sängar och den övre sängen i våningssängar är inte lämpliga för barn under sex år på grund av skaderisk vid fall.;
- WARNING: Våningssängar och upphöjda sängar kan innebära allvarlig risk för strypskador om de inte används på rätt sätt. Fäst eller häng aldrig objekt på någon del av våningssängen som inte är avsedd för användning med nämnda säng. Dessa objekt inkluderar, men är inte begränsade till, rep, snören, band, krok, krokar, bälten och väskor.;
- WARNING: Barn kan fastna mellan sängen och väggen, en del av ett sluttande tak, taket, intilliggande möbler (t.ex. skåp) eller annat. För att undvika risk för allvarliga skador måste avståndet mellan den övre säkerhetsbarriären och de omgivande delarna inte överstiga 75 mm eller måste vara större än 230 mm.
- WARNING: Använd inte våningssängen eller den upphöjda sängen om någon del fattas eller är trasig.
- Se till att alltid följa tillverkarens instruktioner.
- Du rekommenderas att använda en madrass på 190x90 cm.
- "Det är nödvändigt att vädra rummet för att bibehålla en låg luftfuktighet och förhindra att mögel bildas i och runt sängen."
- Madrassen får maximalt vara 18 cm tjock. Kontrollera märkningen som finns på sängen.
- Kontrollera regelbundet att alla fästen är ordentligt tilldragna.
- Uppfyller säkerhetsstandard NF EN 747+A1: 2015.

NO / VIKTIG – LES NØYE – BEHOLD FOR FREMTIDIG REFERANSE

- ADVARSEL Loftsenge og øverste sengen i køyesenge er ikke egnet for barn under seks år på grunn av fare for skader knyttet til fall.
- ADVARSEL Køye- og loftsenge skal brukes som en soveplass, hvis de brukes til andre formål kan de utgjøre en alvorlig fare for skade ved kvelning. Ikke heng eller skru fast gjenstander som ikke er tilhørende sengen. Dette gjelder bl.a. tau, snorer, tauløkker, krokar, belter eller vesker.
- ADVARSEL Barn kan sette seg fast mellom sengen og en vegg, skråtak, tak, tilstøtende møbler (f.eks skap) eller en annen tilstøtende gjenstand. For å unngå fare for alvorlig skade, må avstanden mellom sengehesten på øverste seng, og de omkringliggende elementene, være under 7,5 cm, eller større enn 23 cm.
- ADVARSEL Ikke ta i bruk køye- eller loftsengen hvis en del av strukturen mangler eller er ødelagt.
- Følg alltid instruksjonene fra produsenten.
- Anbefalt størrelse på madrassen som skal brukes med sengen er 190 x 90 cm.
- Det er nødvendig å lufte rommet regelmessig for å opprettholde lav fuktighet, og hindre utviklingen av mugg i og rundt sengen.
- Madrassen skal ha en maksimal tykkelsen på 18 cm. Se sikkerhetsmerkingen på sengen.
- Sjekk at alle elementene er riktig festet og strammet.
- Oppfyller sikkerhetskravene for standard NF EN 747+A1: 2015.

IT / IMPORTANTE - LEGGERE ATTENTAMENTE - DA CONSERVARE PER UN'ULTERIORE CONSULTAZIONE

- AVVERTENZE I letti a soppalco ed il letto superiore dei letti a castello non sono adatti ai bambini di età inferiore ai sei anni per i rischi di lesioni dovute a cadute
- AVVERTENZE Se non utilizzati correttamente, i letti a castello ed i letti a soppalco possono rappresentare un importante rischio di lesioni da strangolamento. Non legare o sospendere mai elementi a delle parti del letto a castello che non siano previsti per essere utilizzati con il suddetto letto. Questi elementi comprendono, senza tuttavia esserne limitati, le corde, gli spaghi, i cordoncini, i ganci, le cinghie ed i sacchi
- AVVERTENZE I bambini possono ritrovarsi bloccati tra il letto ed un muro, la parte di un tetto inclinato, il soffitto, i mobili adiacenti (per esempio gli armadi) o altro. Per evitare qualsiasi rischio di lesione grave, la distanza tra la sponda di sicurezza superiore e gli elementi circostanti non deve superare 75 mm o deve essere superiore a 230 mm
- AVVERTENZE Non utilizzare il letto a castello o il letto a soppalco se un pezzo della struttura manca o se è rotto. I pezzi di ricambio devono essere richiesti al fabbricante o al negoziante.
- Seguire rigorosamente le istruzioni di montaggio e d'uso del fabbricante
- La misura consigliata del materasso da usare con il letto è di 190 x 90 cm, Spessore massimo del materasso : 18 cm.
- Per mantenere un livello poco elevato di umidità, e per impedire lo sviluppo di muffa nel letto e intorno al letto, ventilare la stanza,
- I dispositivi d'assemblaggio devono sempre essere adeguatamente stretti e regolarmente verificati. Ristringerli se necessario.
- Conforme alle esigenze europee di sicurezza della norma NF EN 747+A1: 2015.
- la presenza di una luce notturna può dare più sicurezza al bambino che dorme nel letto superiore

RU / ВАЖНО — ПРОЧИТАЙТЕ ВНИМАТЕЛЬНО — СОХРАНИТЕ ДЛЯ ДАЛЬНЕЙШЕГО ИСПОЛЬЗОВАНИЯ

- ПРЕДУПРЕЖДЕНИЕ Кровати-чердаки и верхние ярусы двухъярусных кроватей не подходят для детей в возрасте до шести лет из-за опасности травм, связанных с падениями. ;
- ПРЕДУПРЕЖДЕНИЕ При неправильном использовании двухъярусные кровати и кровати-чердаки могут представлять серьезную опасность удушья. Никогда не прикрепляйте и не подвешивайте к частям двухъярусной кровати никакие элементы, которые не предназначены для использования вместе с ней, в том числе веревки, бечевки, шнуры, крючки, ремни, сумки и любые другие предметы. ;
- ПРЕДУПРЕЖДЕНИЕ Дети могут застрять между кроватью и стеной, частью покатой крыши, потолком, прилегающей мебелью (например, стенными шкафами) и др. Во избежание серьезных травм расстояние между верхним защитным барьером и окружающими элементами должно быть менее 75 мм или более 230 мм. ;
- ПРЕДУПРЕЖДЕНИЕ Не используйте двухъярусную кровать или кровать-чердак, если какая-либо часть конструкции отсутствует или сломана. ;
- Всегда следуйте инструкциям производителя.
- Рекомендуемый размер матраса для использования с кроватью составляет 190 x 90 см.
- Необходимо проветривать помещение, чтобы поддерживать в нем низкий уровень влажности и тем самым предотвратить возникновение плесени на кровати и вокруг нее.
- Матрас должен иметь толщину не более 18 см. Ориентируйтесь, пожалуйста, на приведенную на кровати пометку.
- Регулярно проверяйте, все ли крепежные детали затянуты должным образом.
- Изделие соответствует тр

LIT SUPERPOSE

CONFORME AUX EXIGENCES DE SECURITE
NORMES NF EN 747-1 ET 2 (2012) + A1 2015

Pour

La Redoute

57, Rue de Blanchemaille
59082 ROUBAIX CEDEX 2
France

REF: 325.7716

LOT:

Le couchage en hauteur ne convient
Pas à un enfant de moins de 6 ans

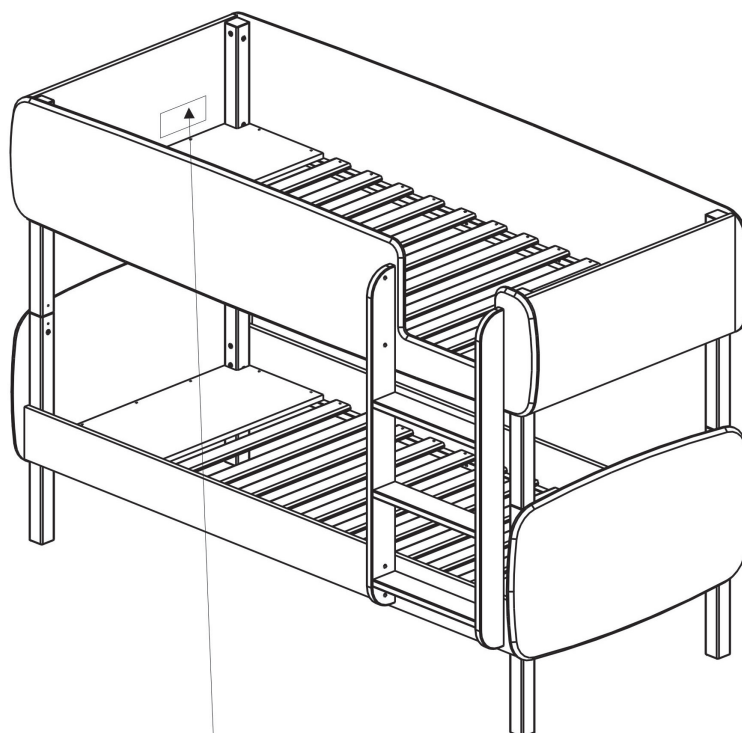

LIT SUPERPOSE

CONFORME AUX EXIGENCES DE SECURITE
NORMES NF EN 747-1 ET 2 (2012) + A1 2015

Pour

La Redoute

57, Rue de Blanchemaille
59082 ROUBAIX CEDEX 2
France

REF: 325.7716

LOT:

Le couchage en hauteur ne convient
Pas à un enfant de moins de 6 ans

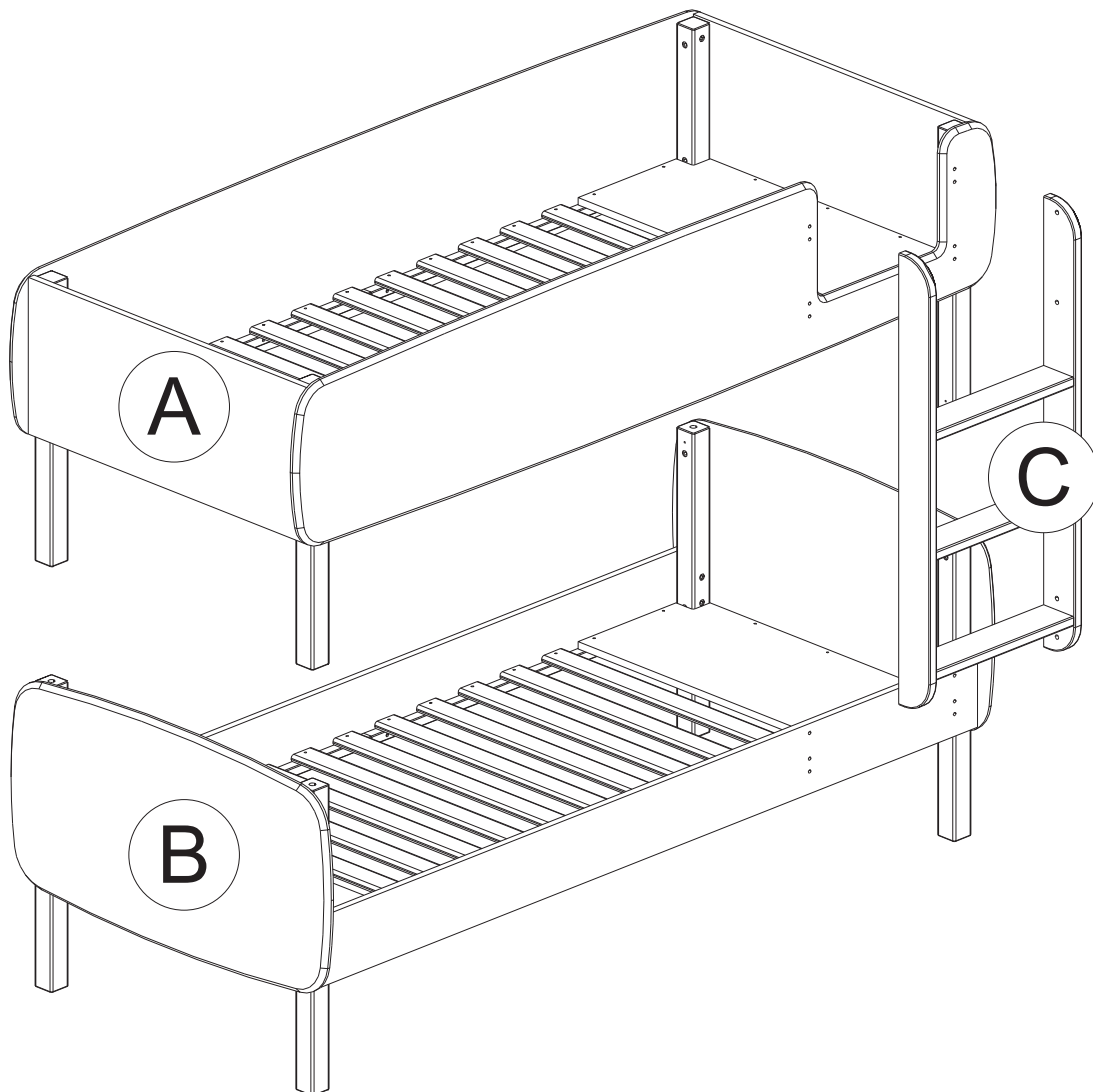

A x 40  10x30

E x 18  8x30

I x 6 

B x 40  M6x65

F x 4  16x75

K x 8  14x15

C x 2 

G x 6  D8x31

L x 2  49 x 67

D x 76  3.5x35

H x 6  M6x10x18

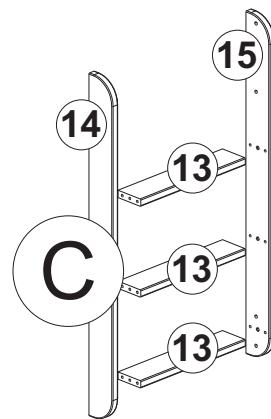
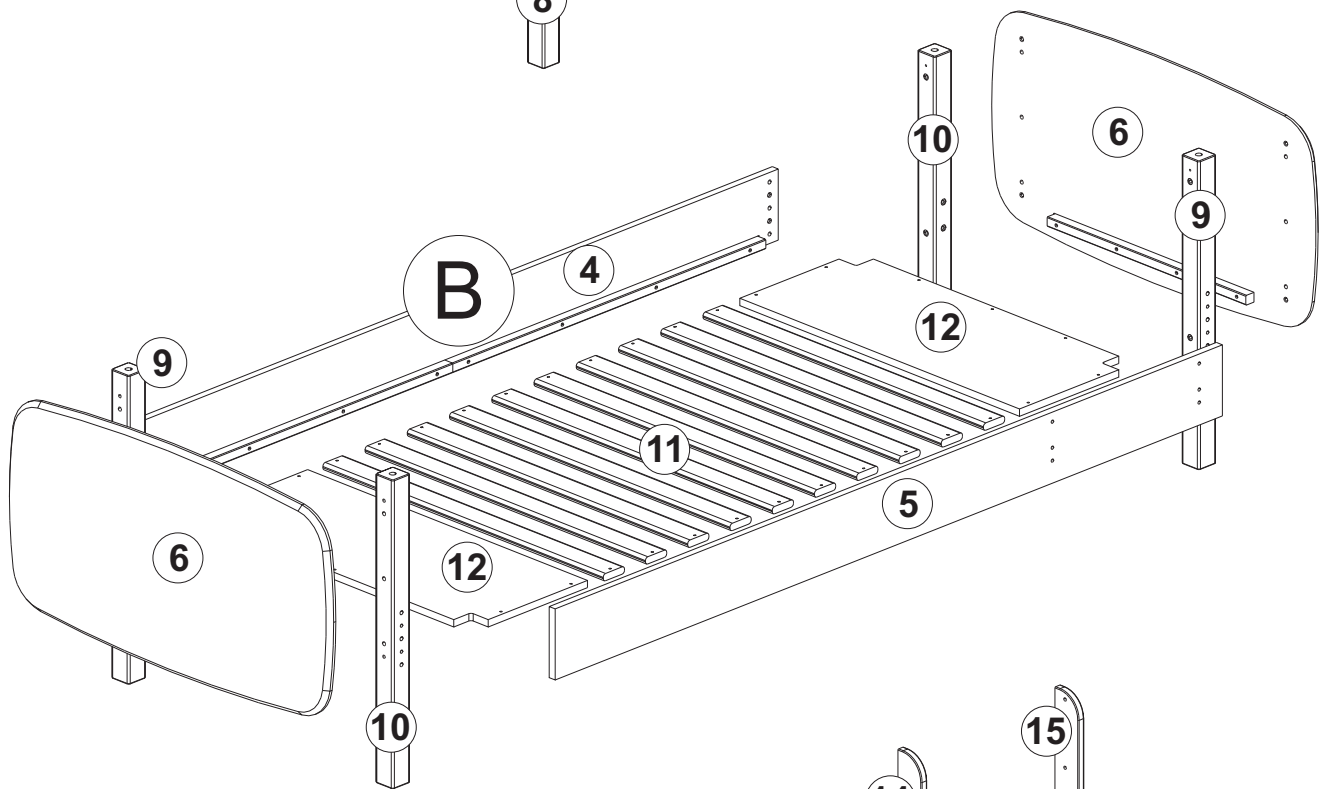
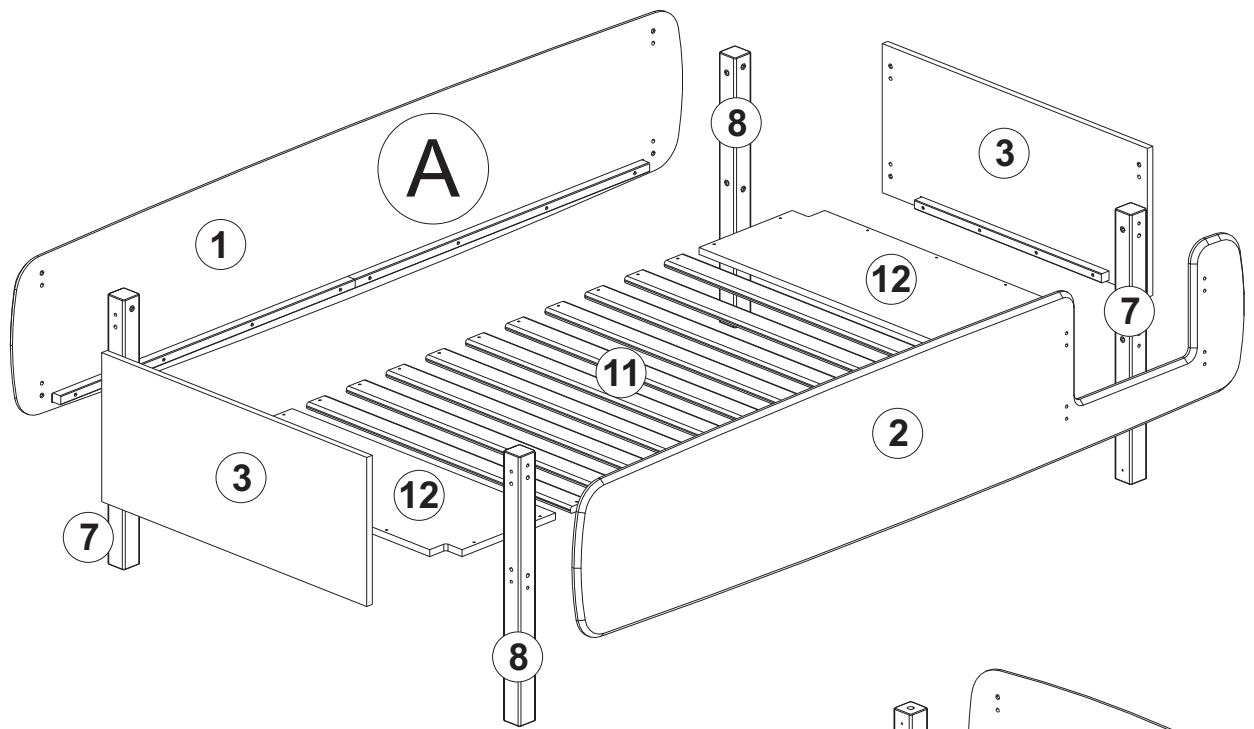

1

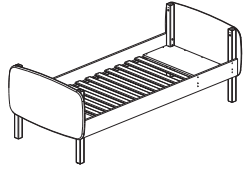

B

A x 24

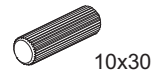

10x30

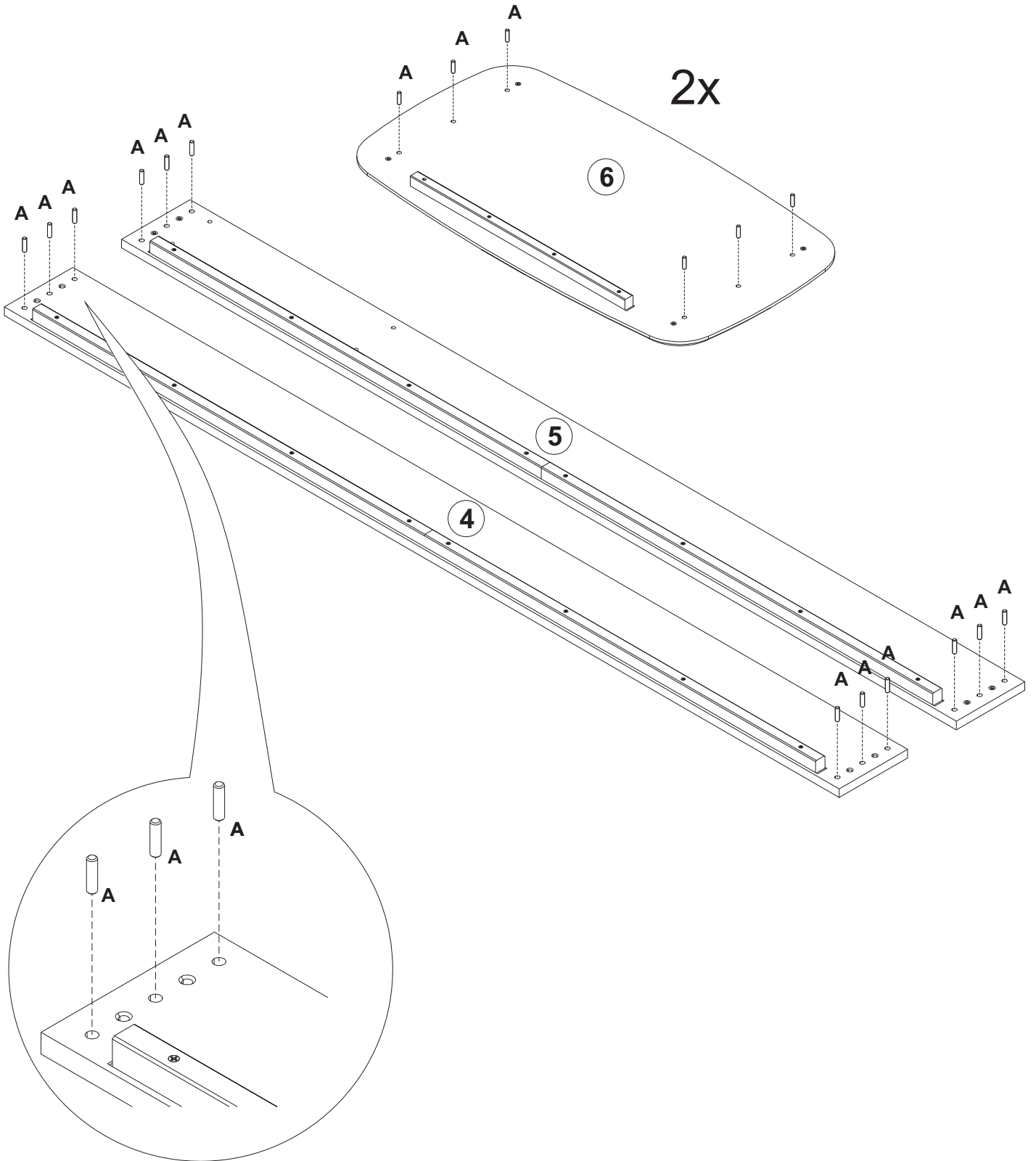
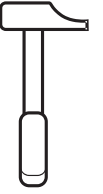

2

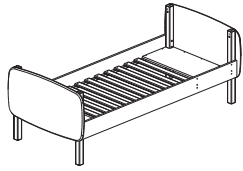

B

B x 8



C x 1

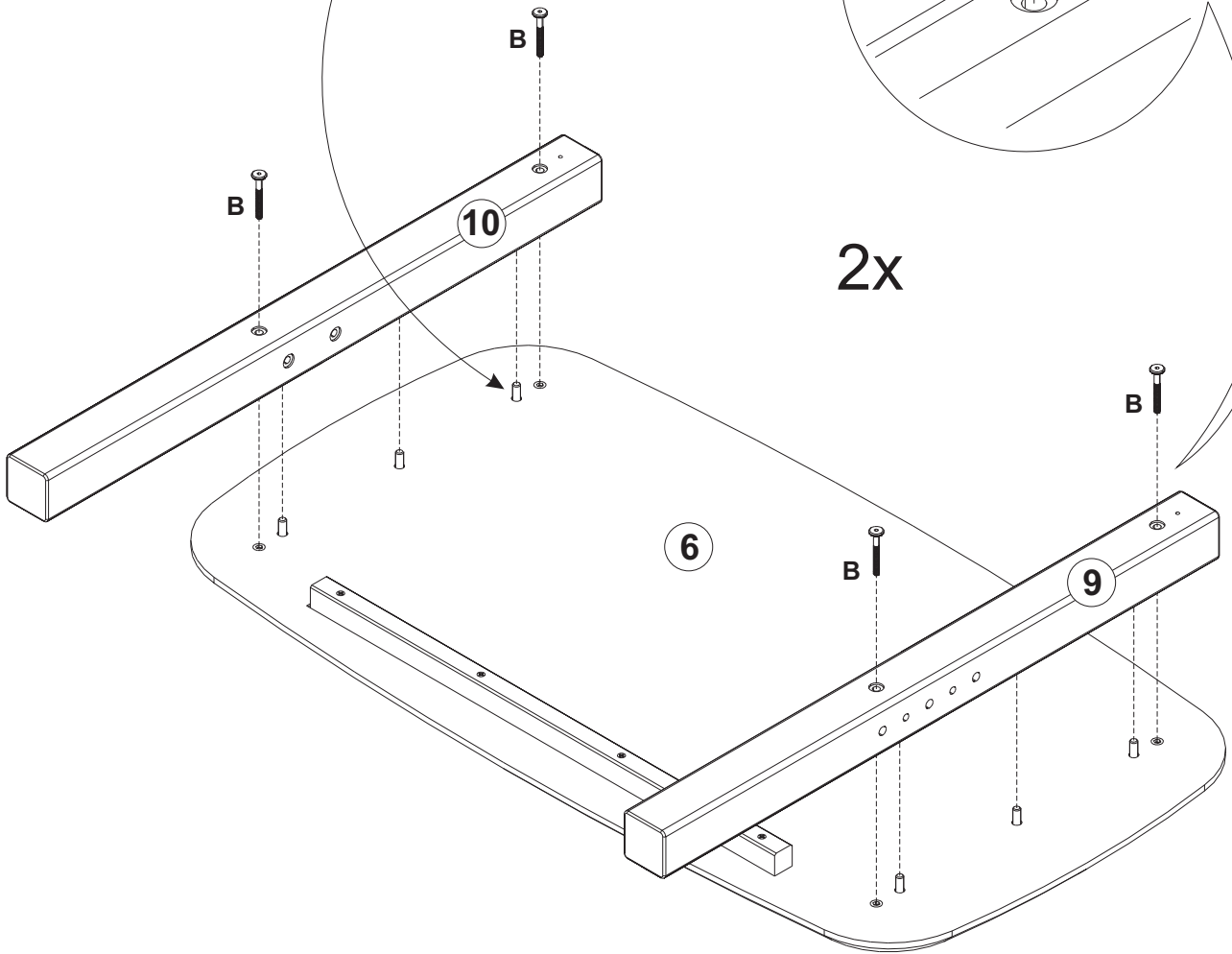
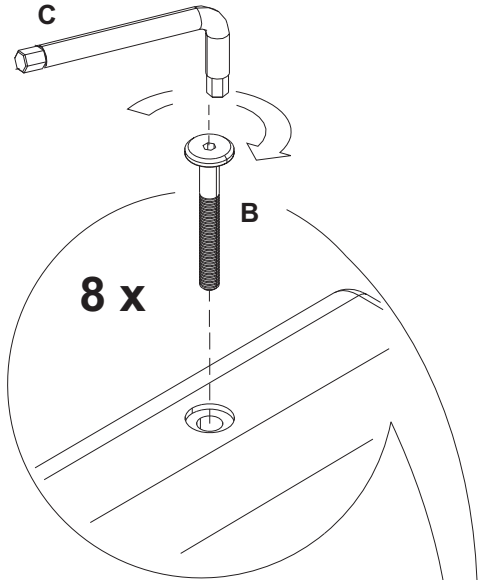
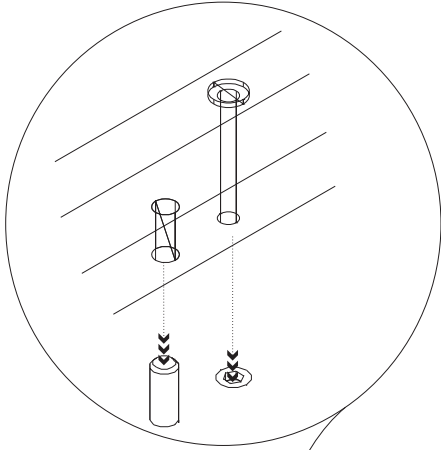

3

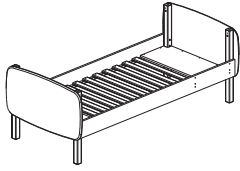

B

B x 8



C x 1

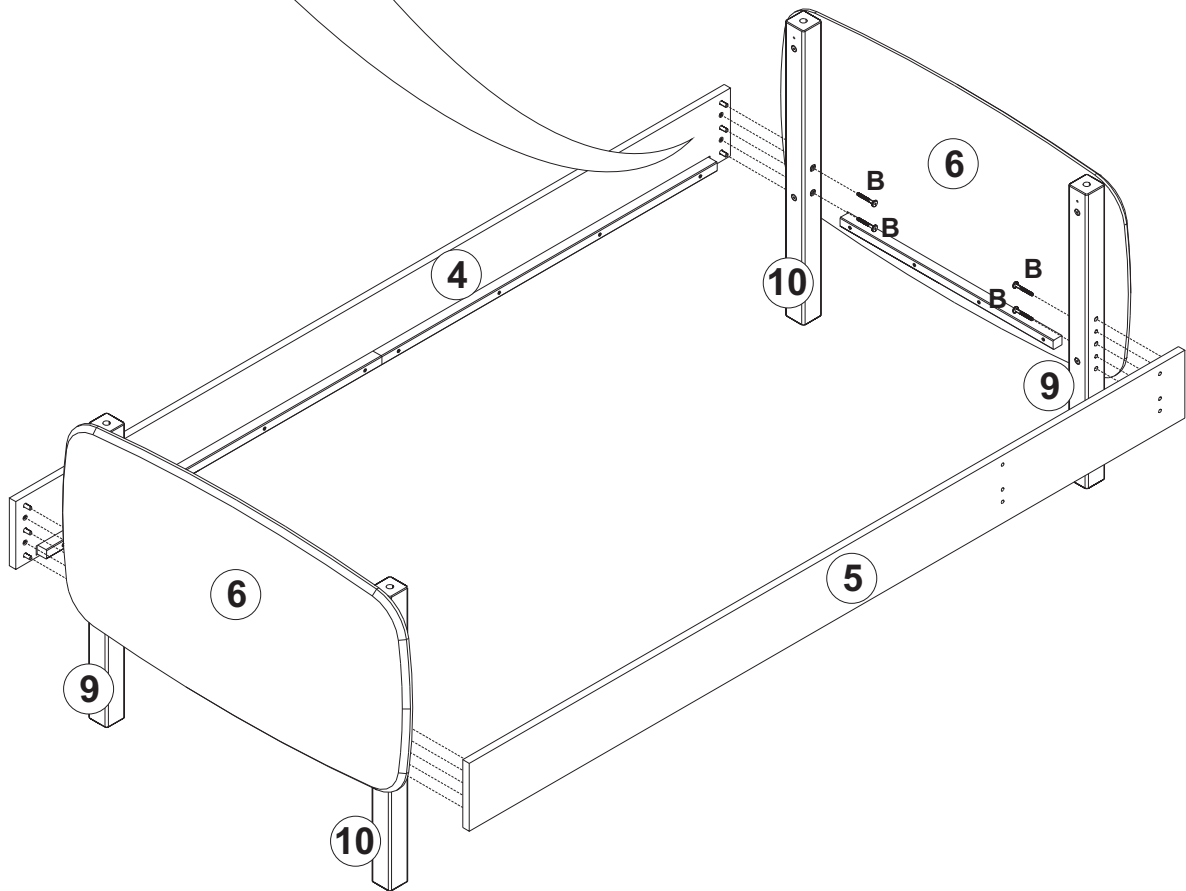
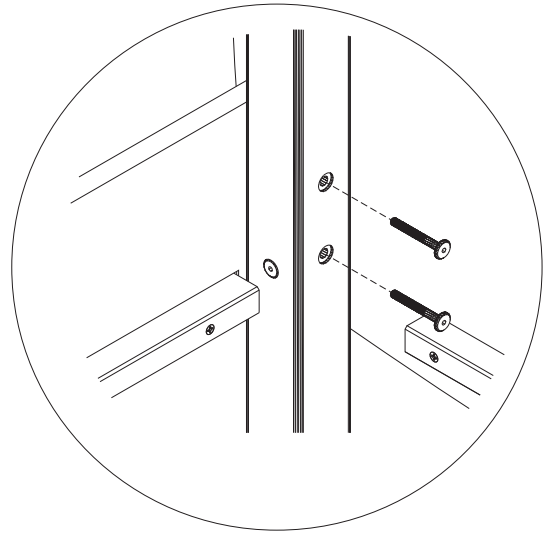
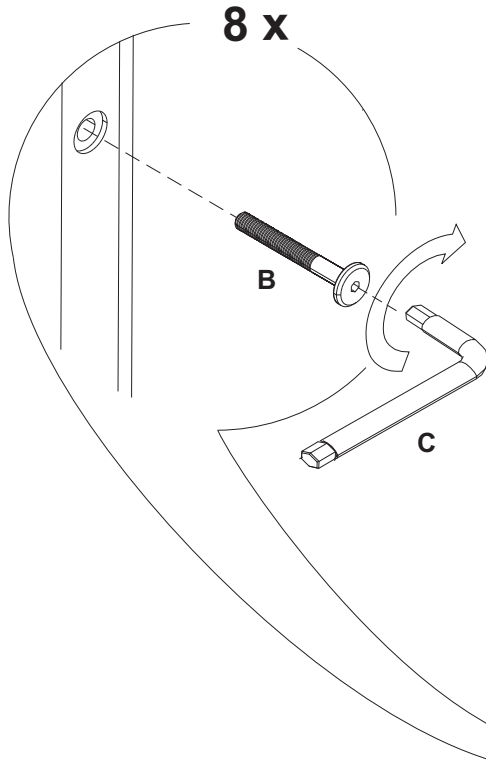

4

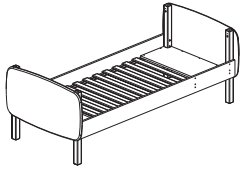

B

D x 14



3.5x35

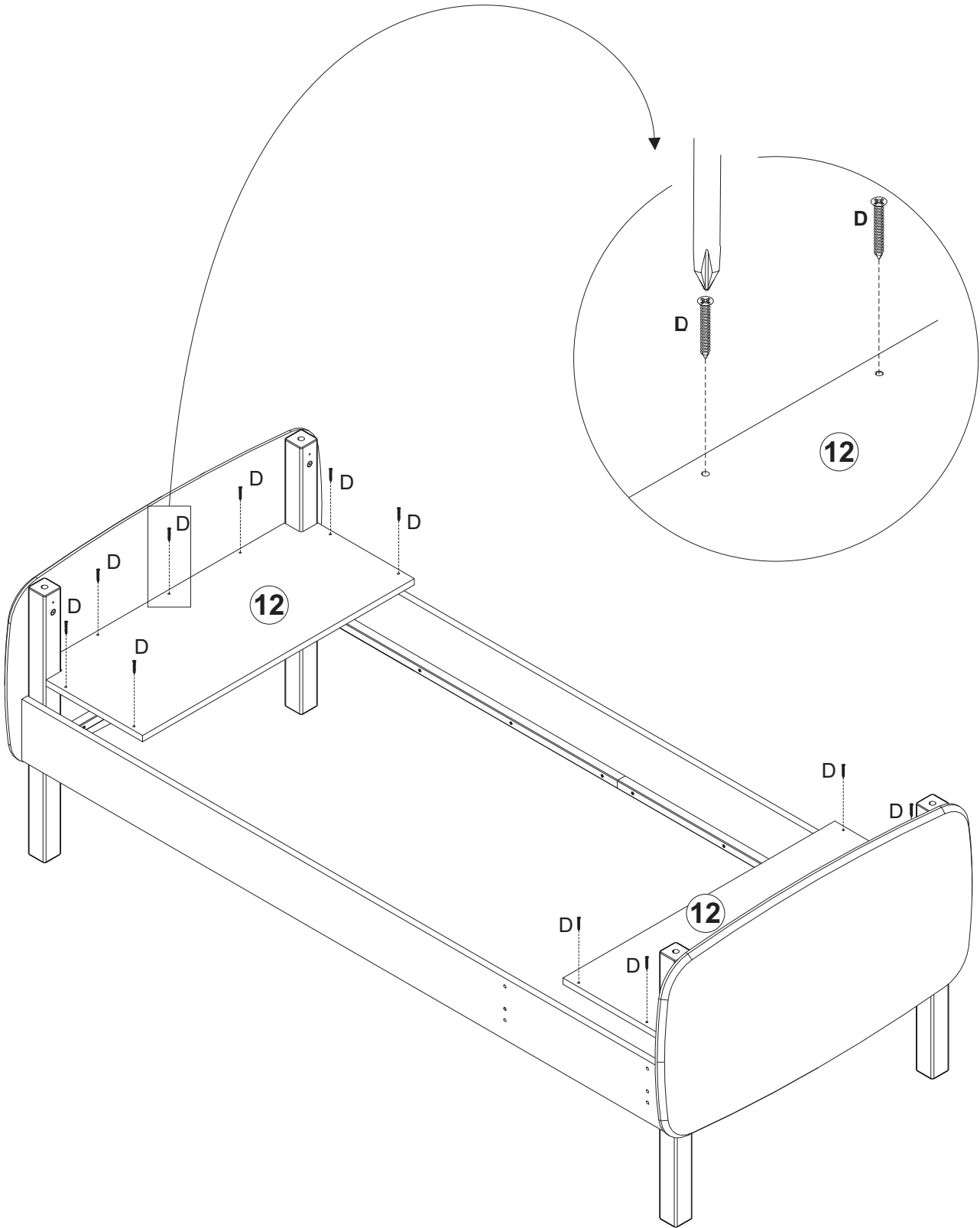

5

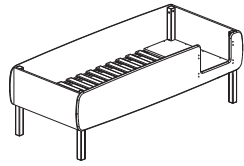

A

A x 16

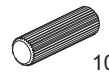

10x30

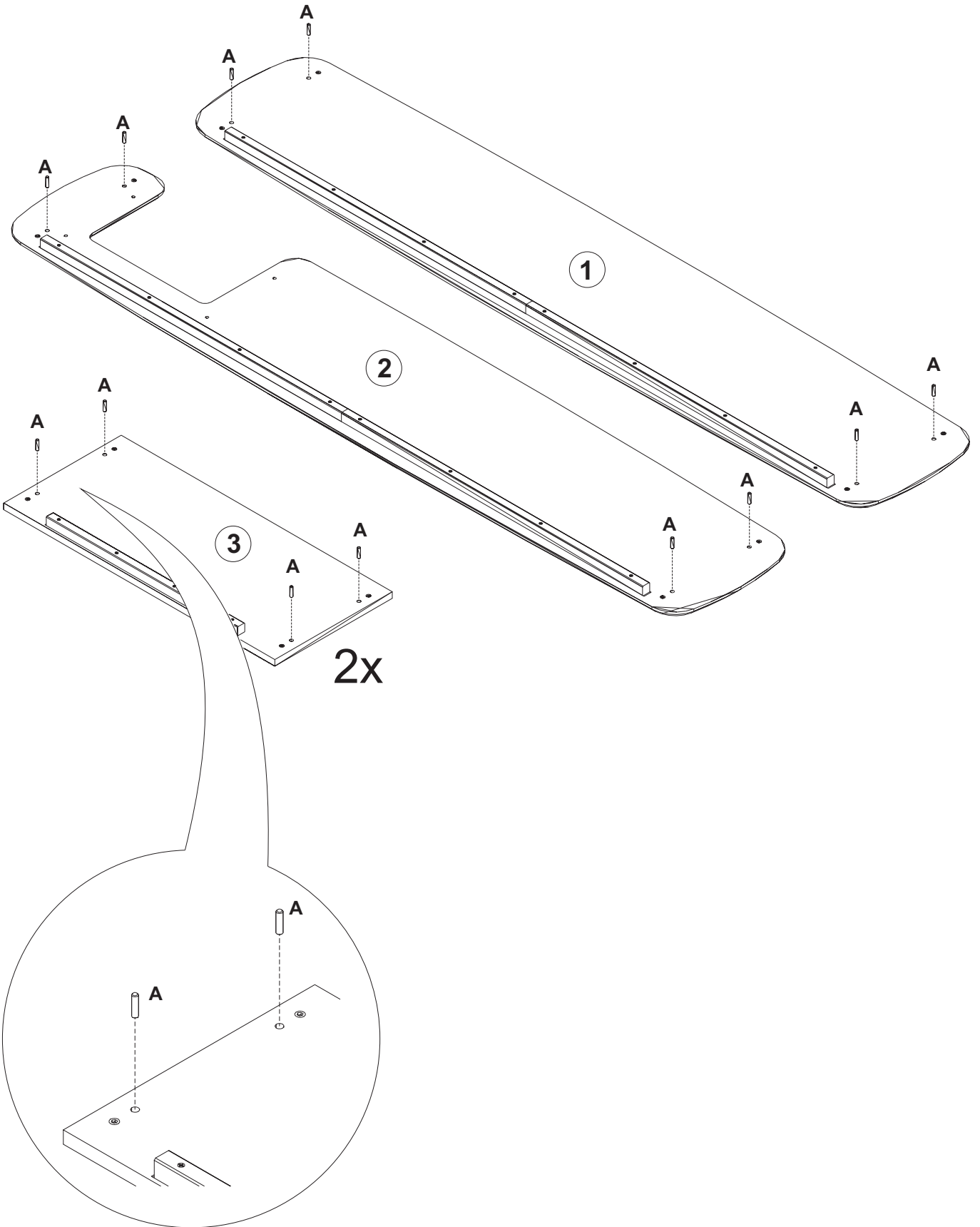
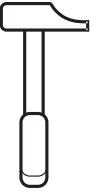

6

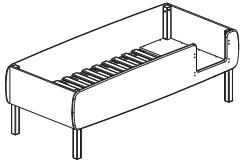

A

B x 8



C x 1

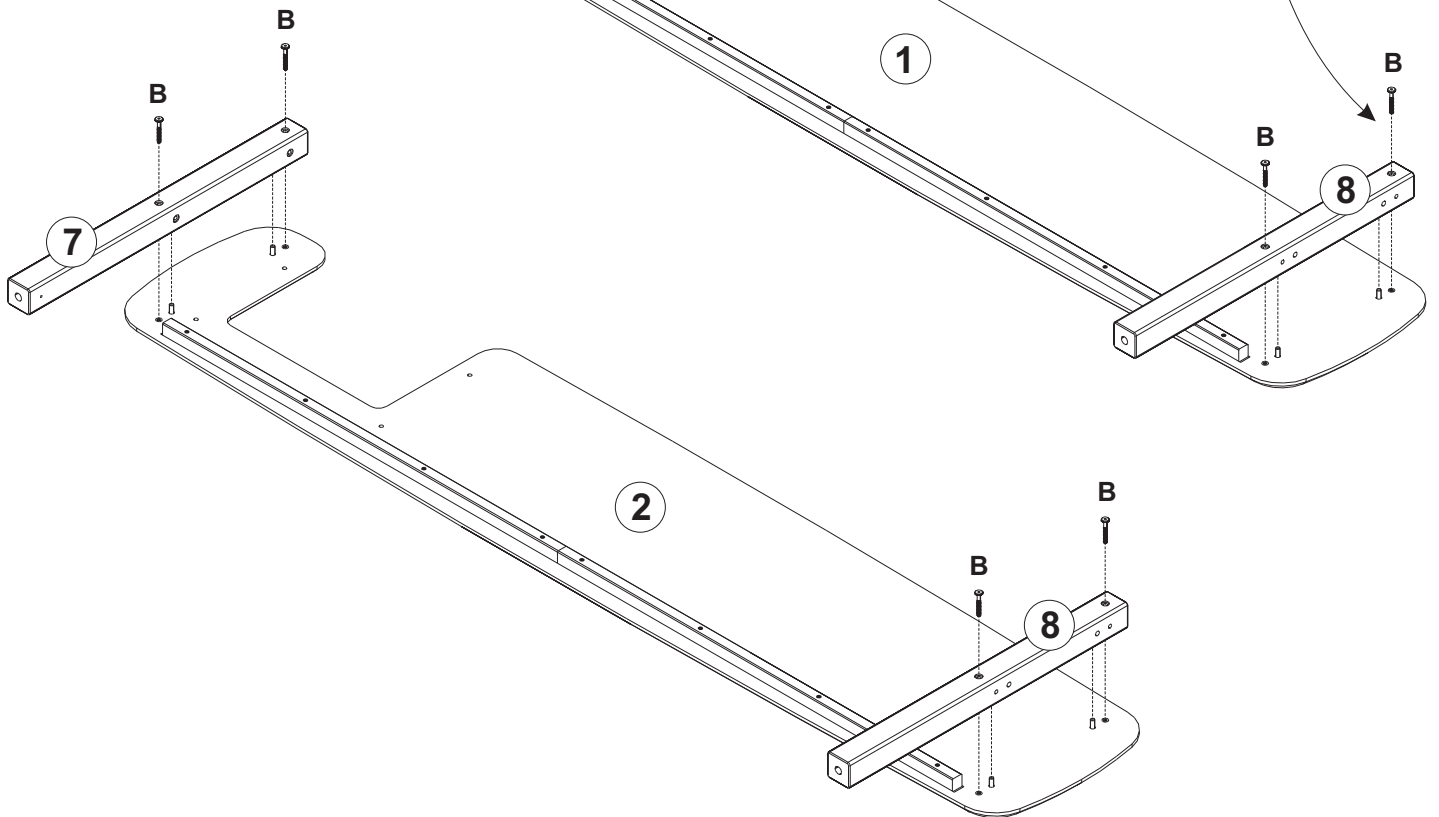
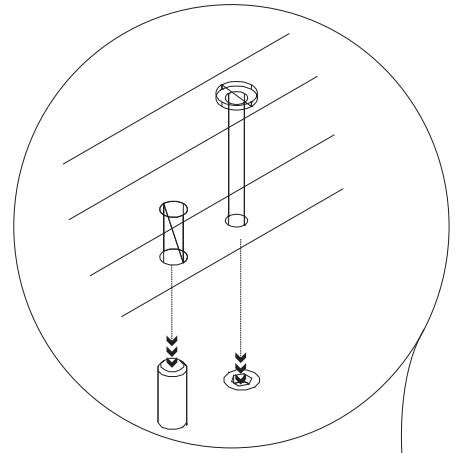
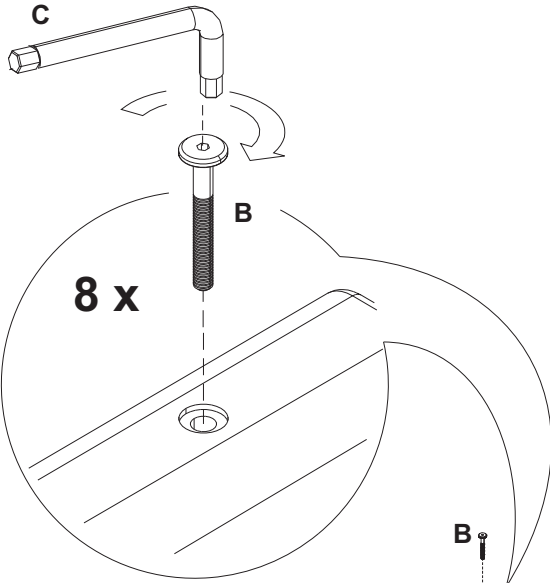

7

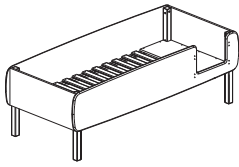

A

B x 8
M6x65

C x 1

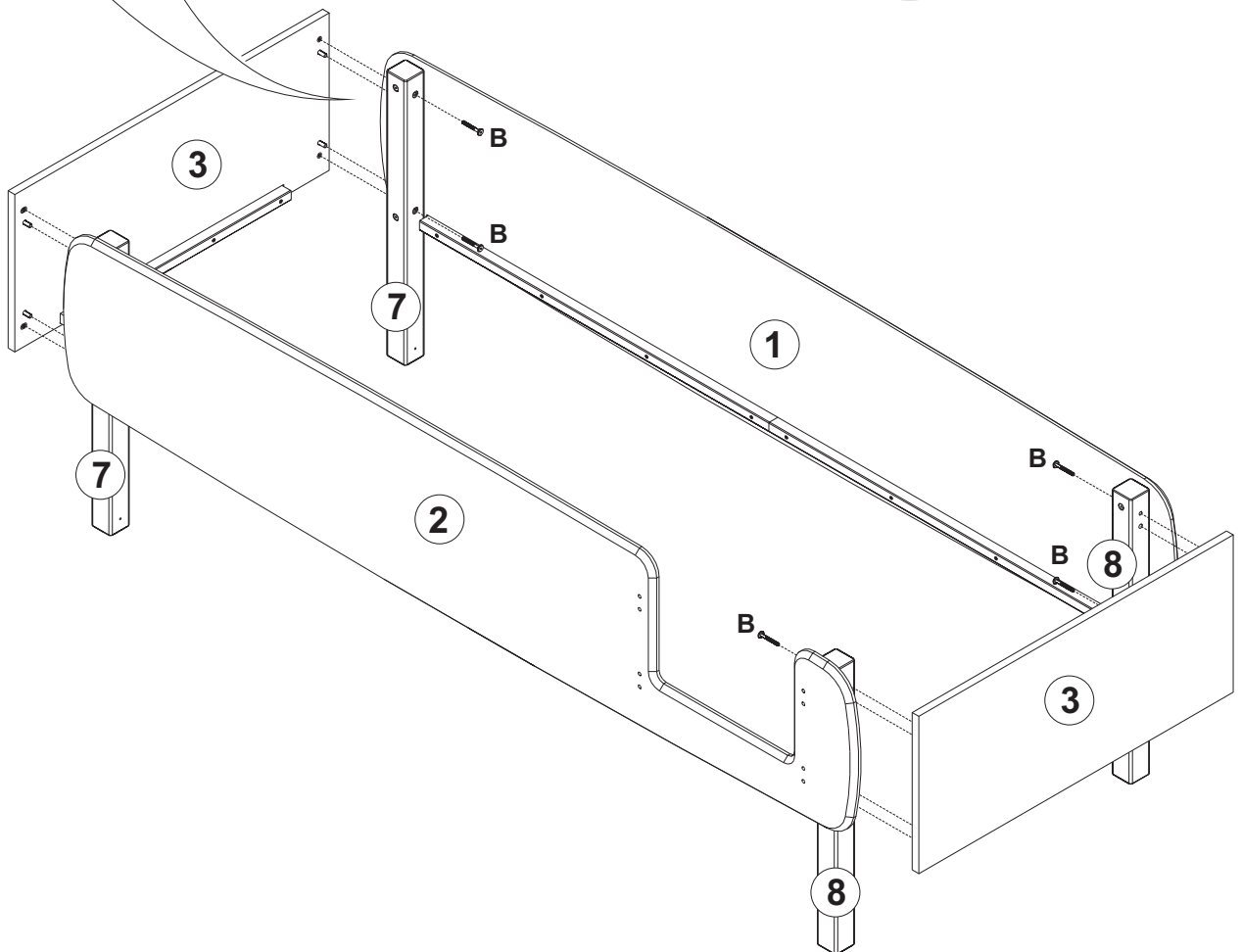
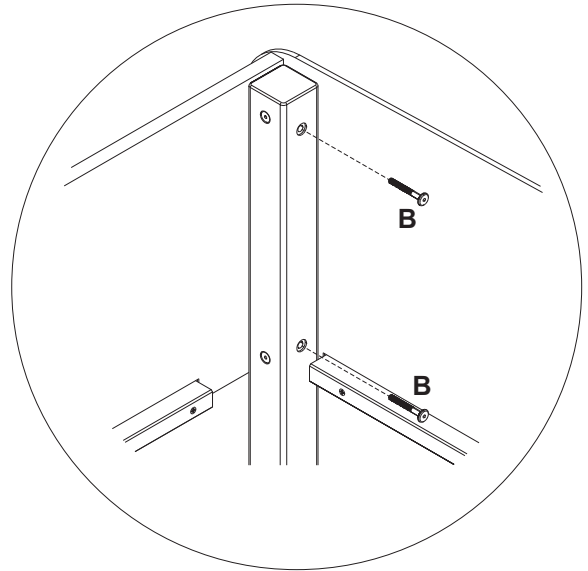
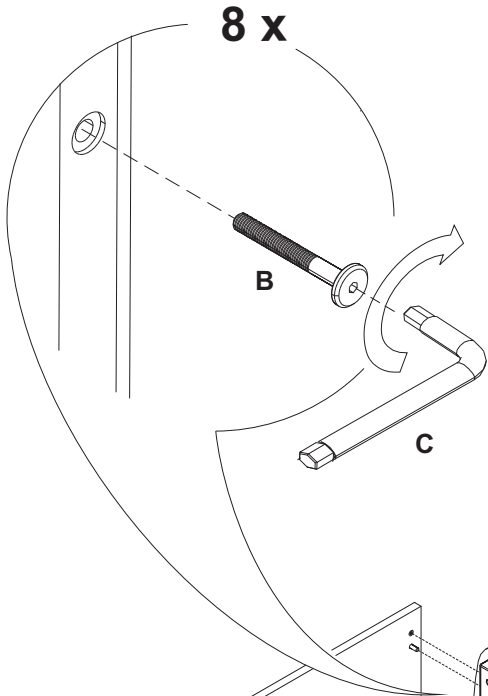

8

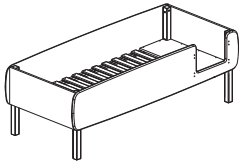

A

Dx14



3.5x35

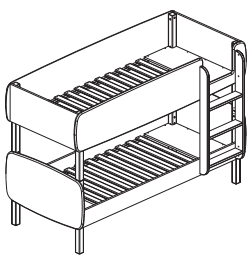
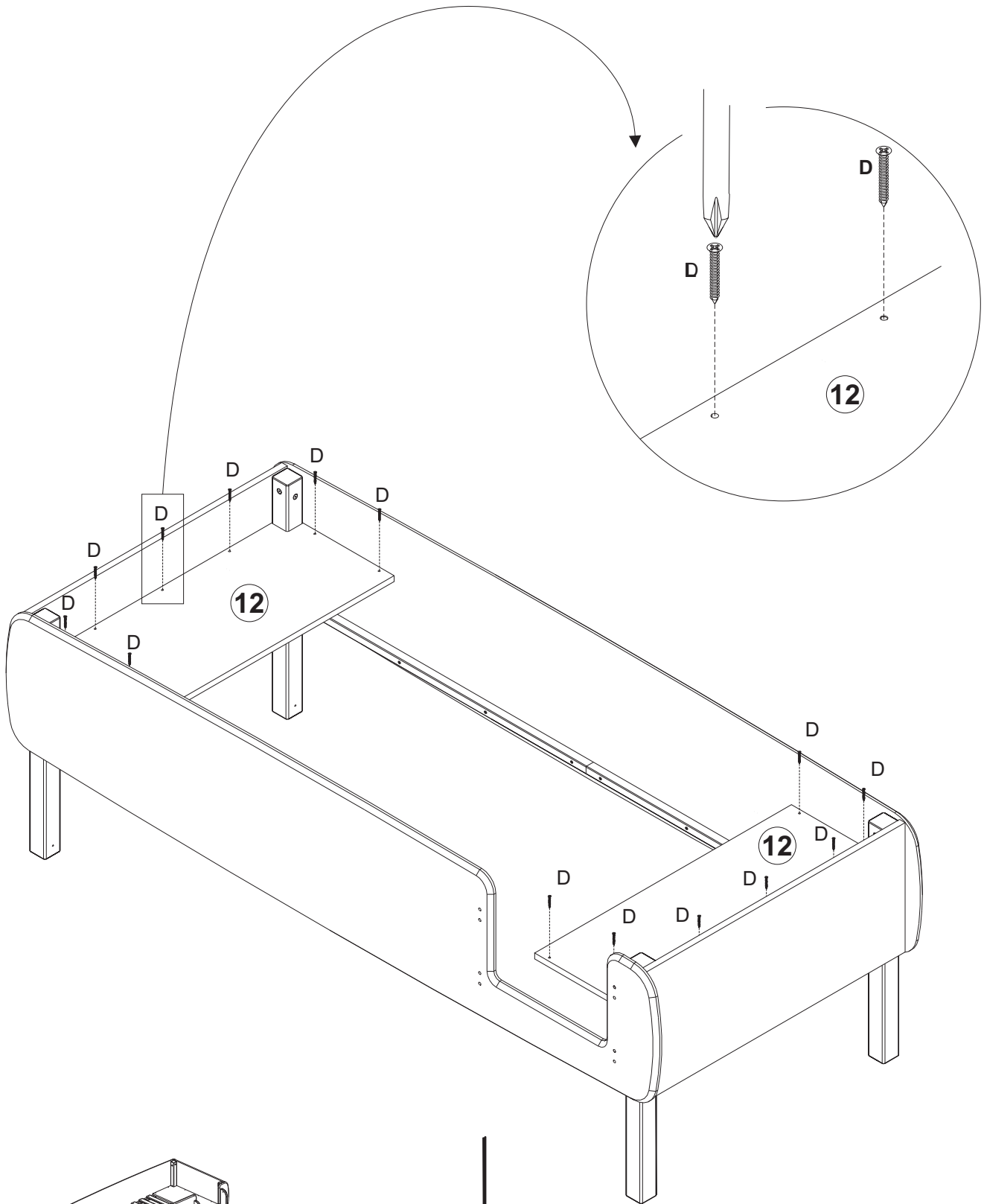

Option 1

9

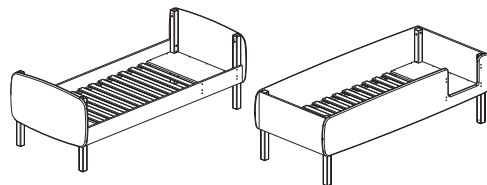

Option 2

15

9

Option 1

F x 4



16x75

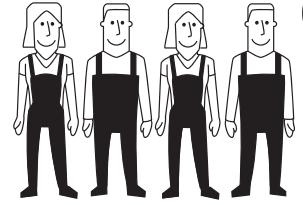

4

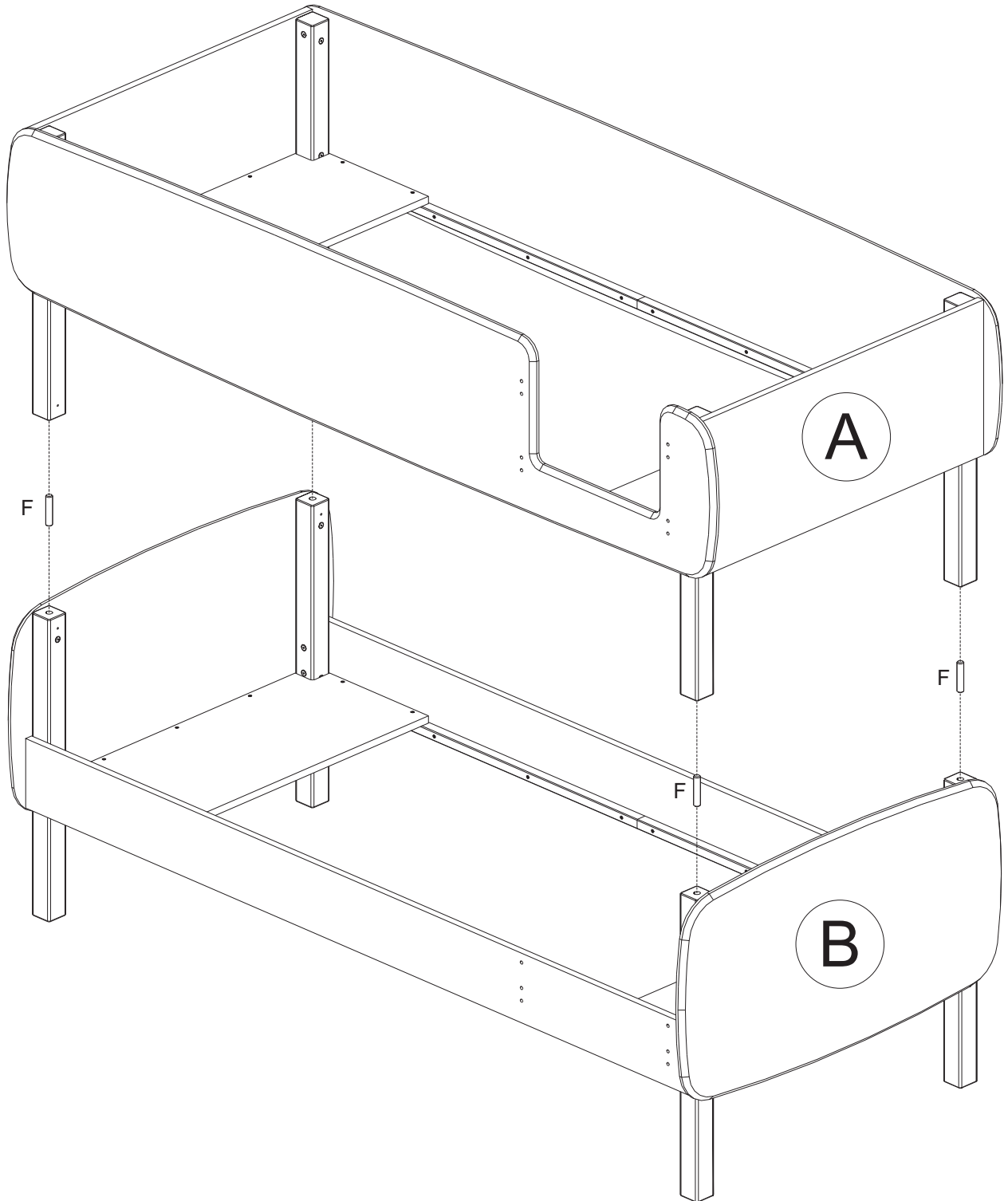

10

Option 1

D x 8

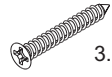

3.5x35

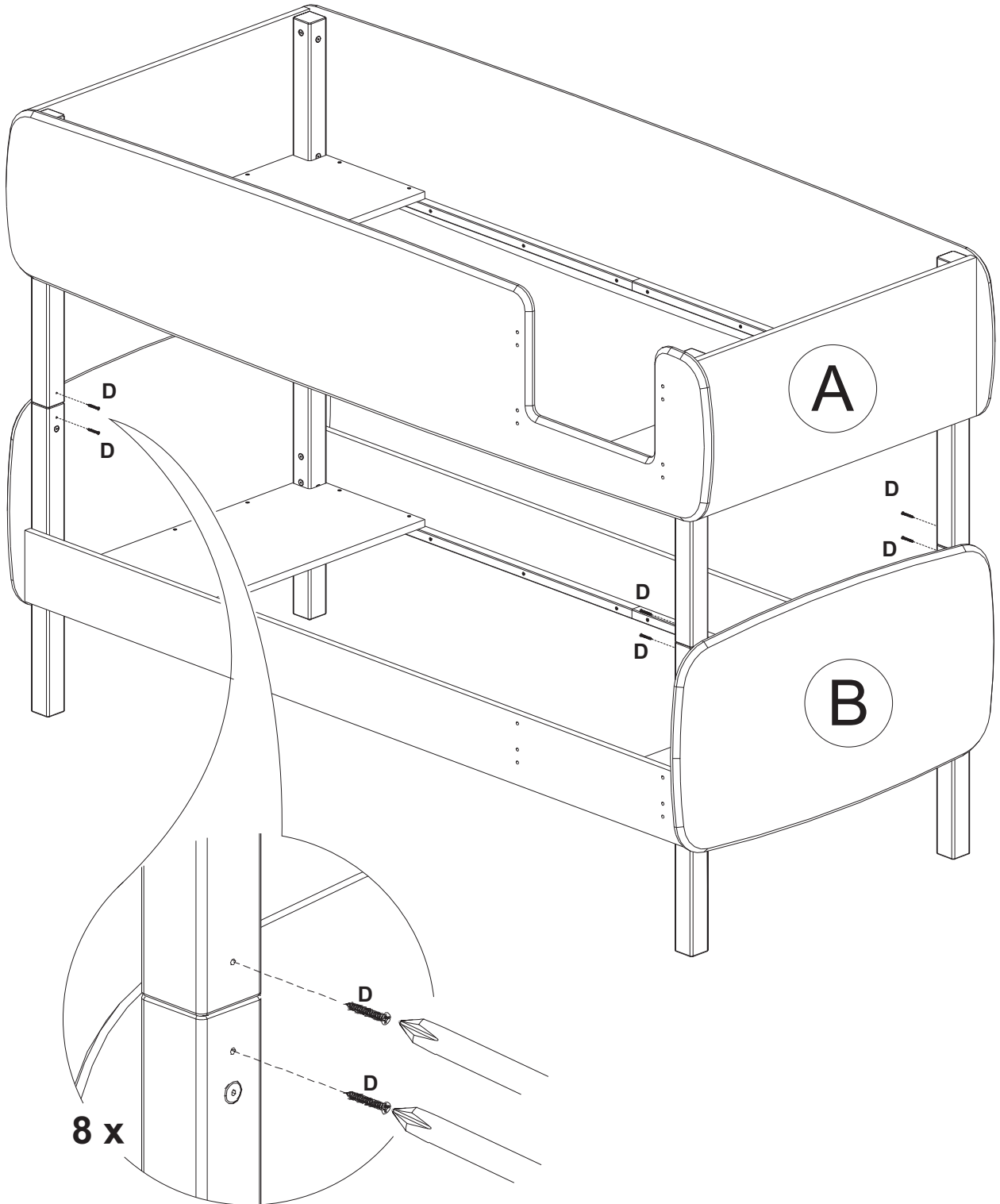

11

Option 1

E x 18



8x30

G x 6



M6x30

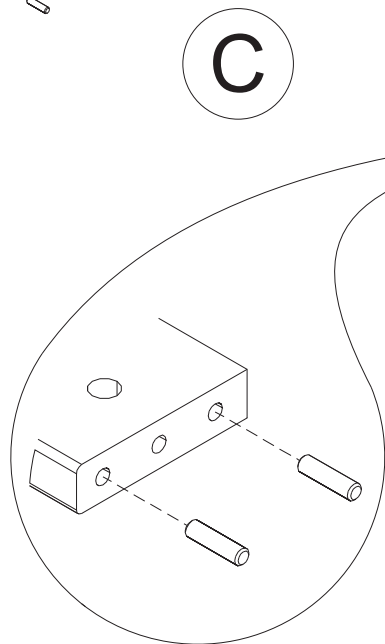
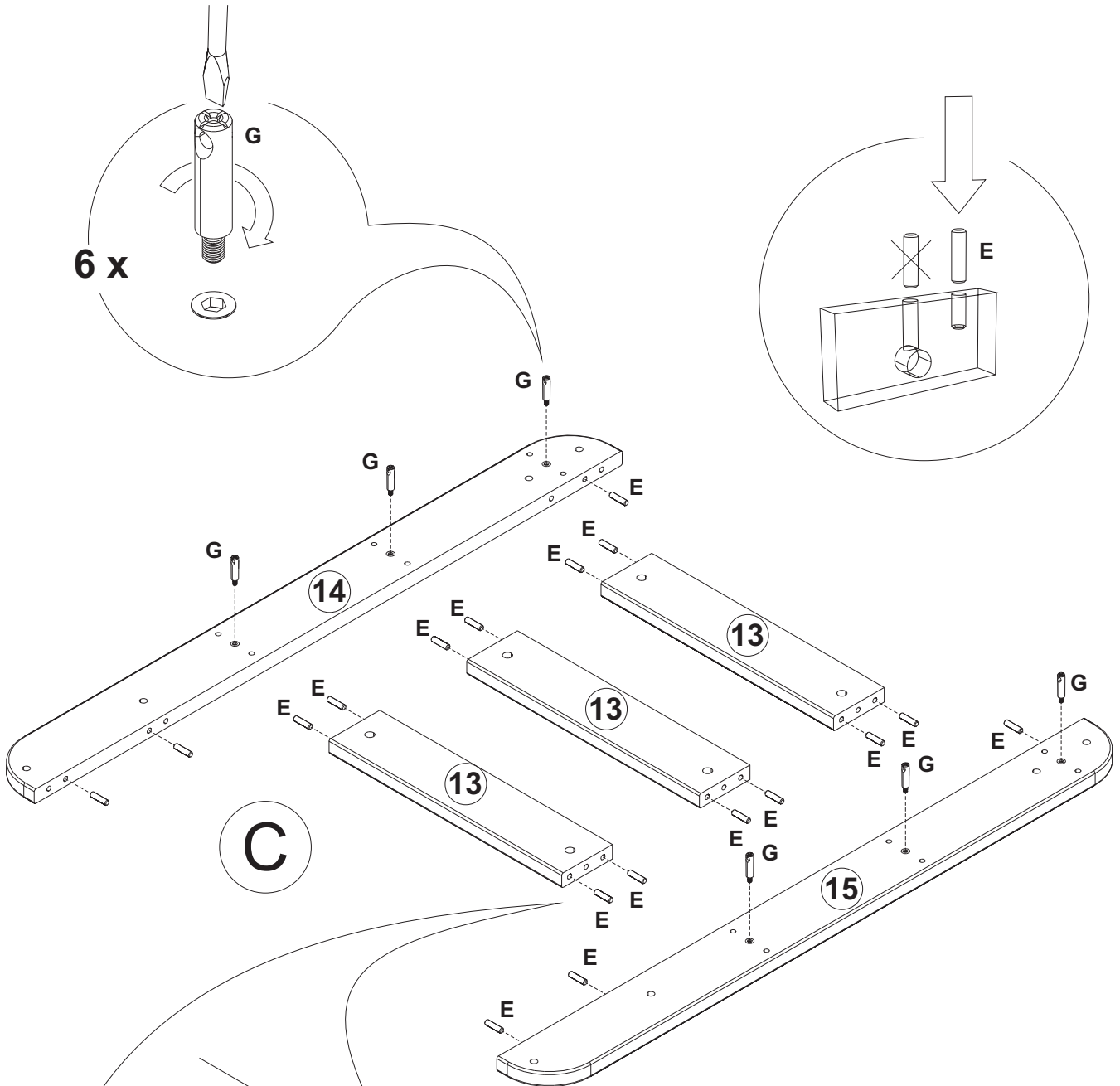
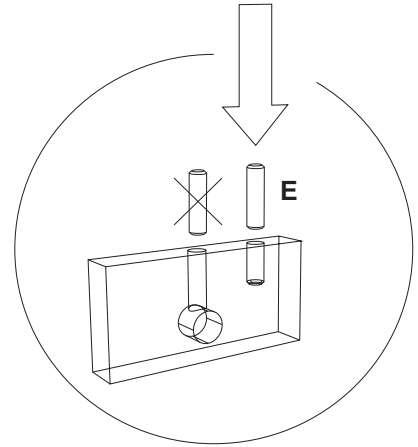
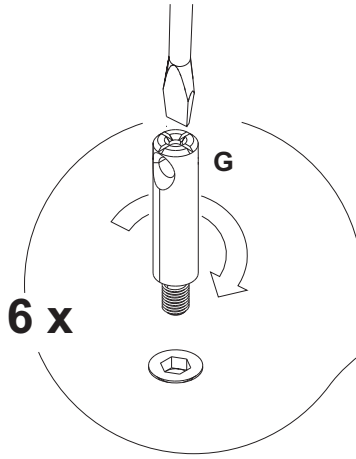
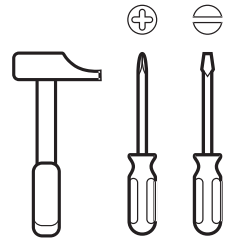

12

Option 1

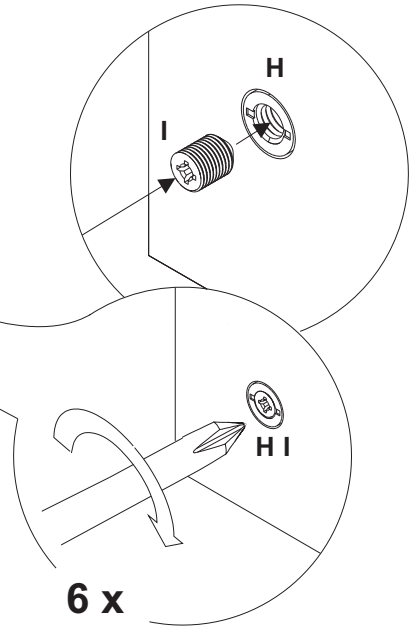
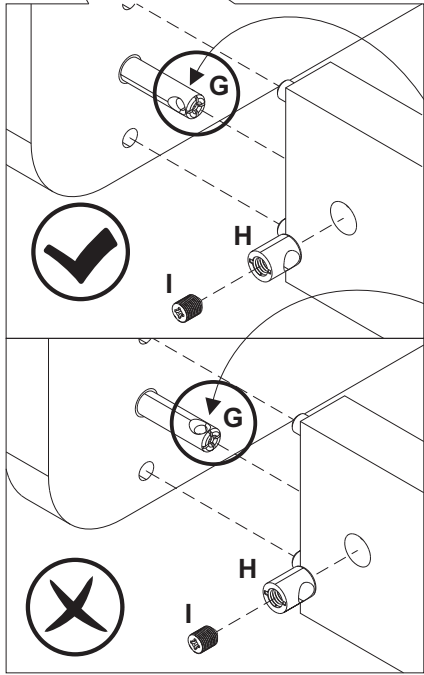
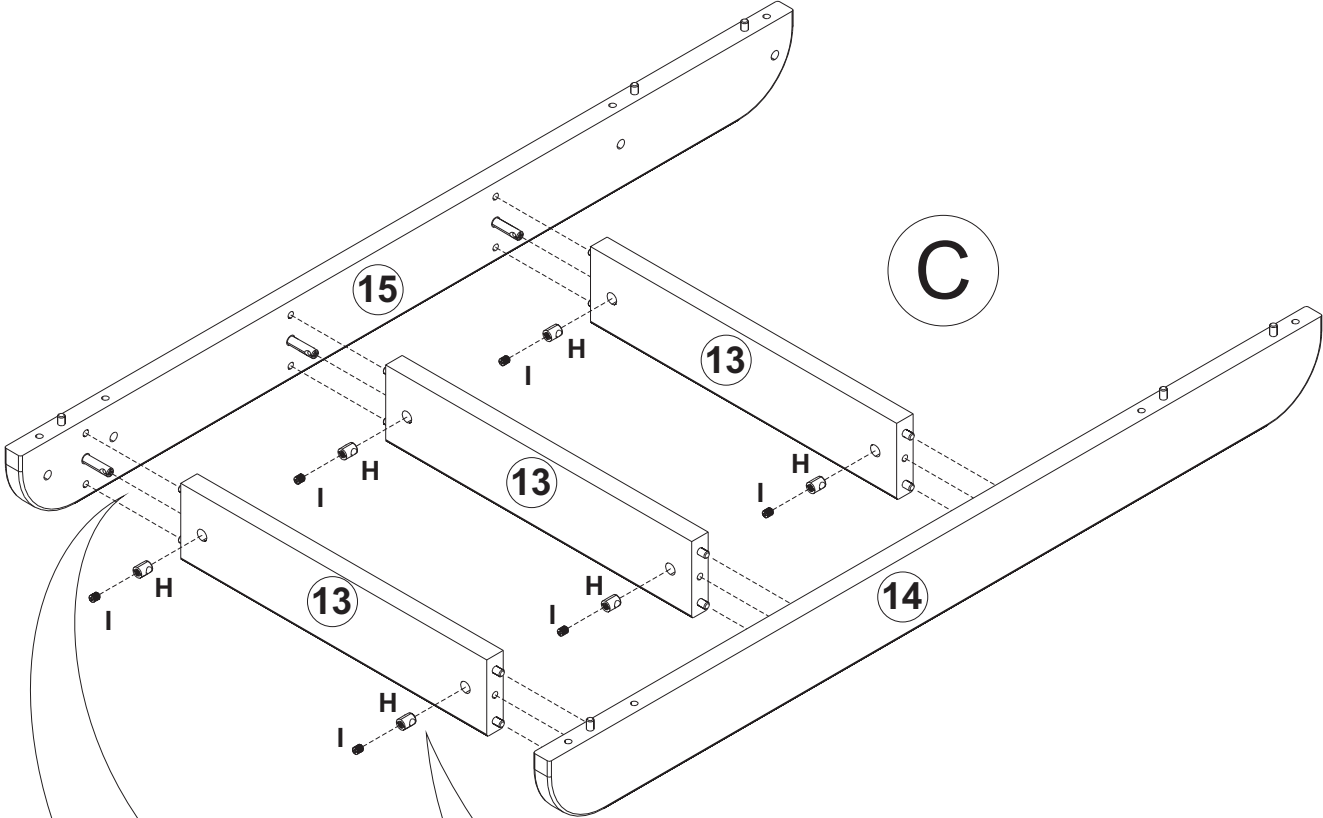
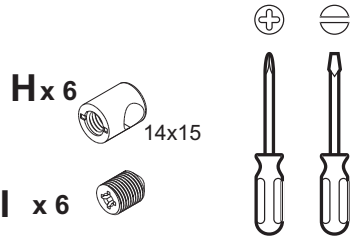

13

Option 1

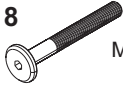
B x 8  M6x65

C x 1 

K x 8  M6x10x18

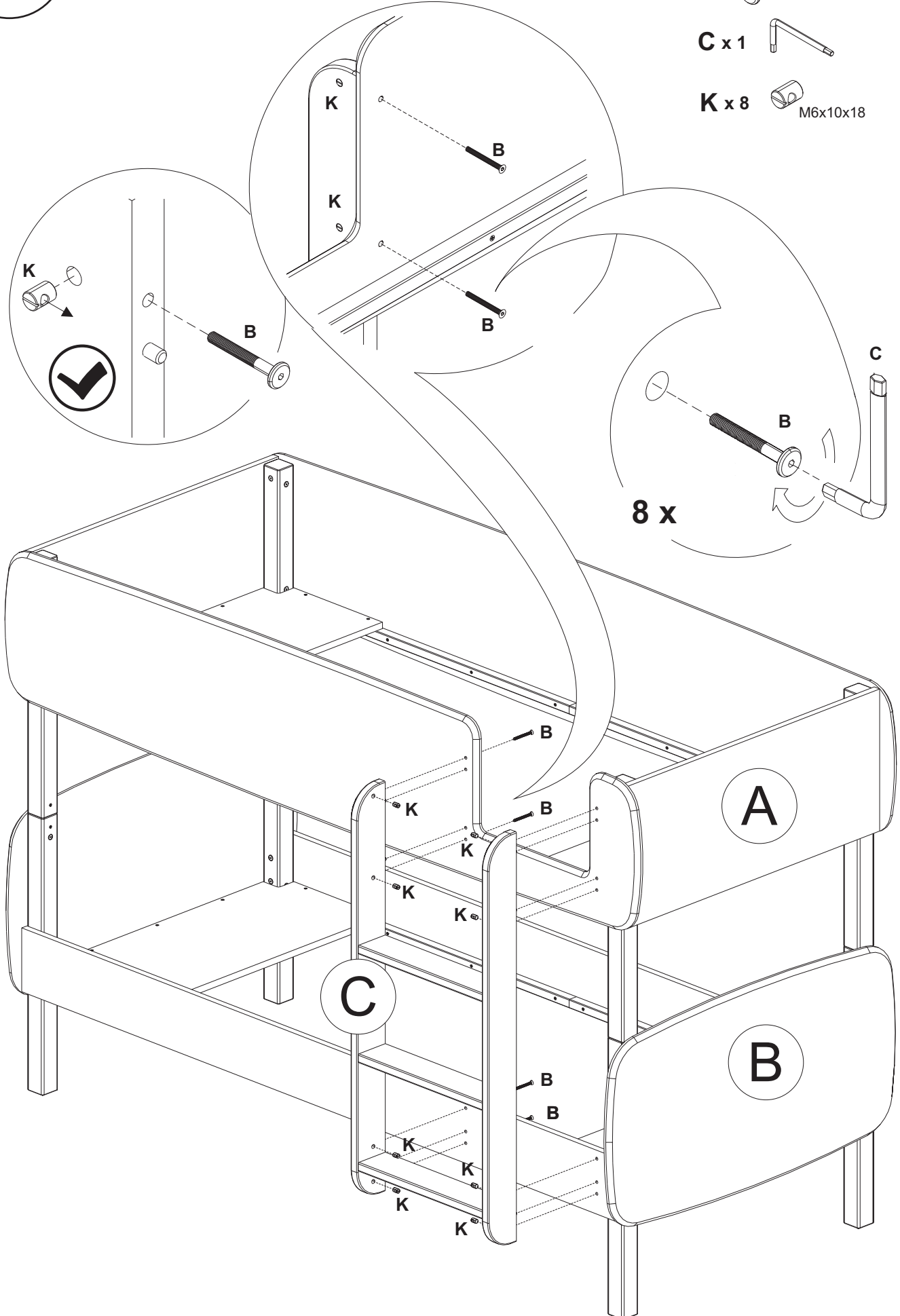

8 x

A

B

C

K

K

K

K

K

K

K

K

K

K

B

B

B

B

B

B

B

C

B

14

Option 1

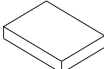
D x 40  3.5x35
L x 2  49 x 67

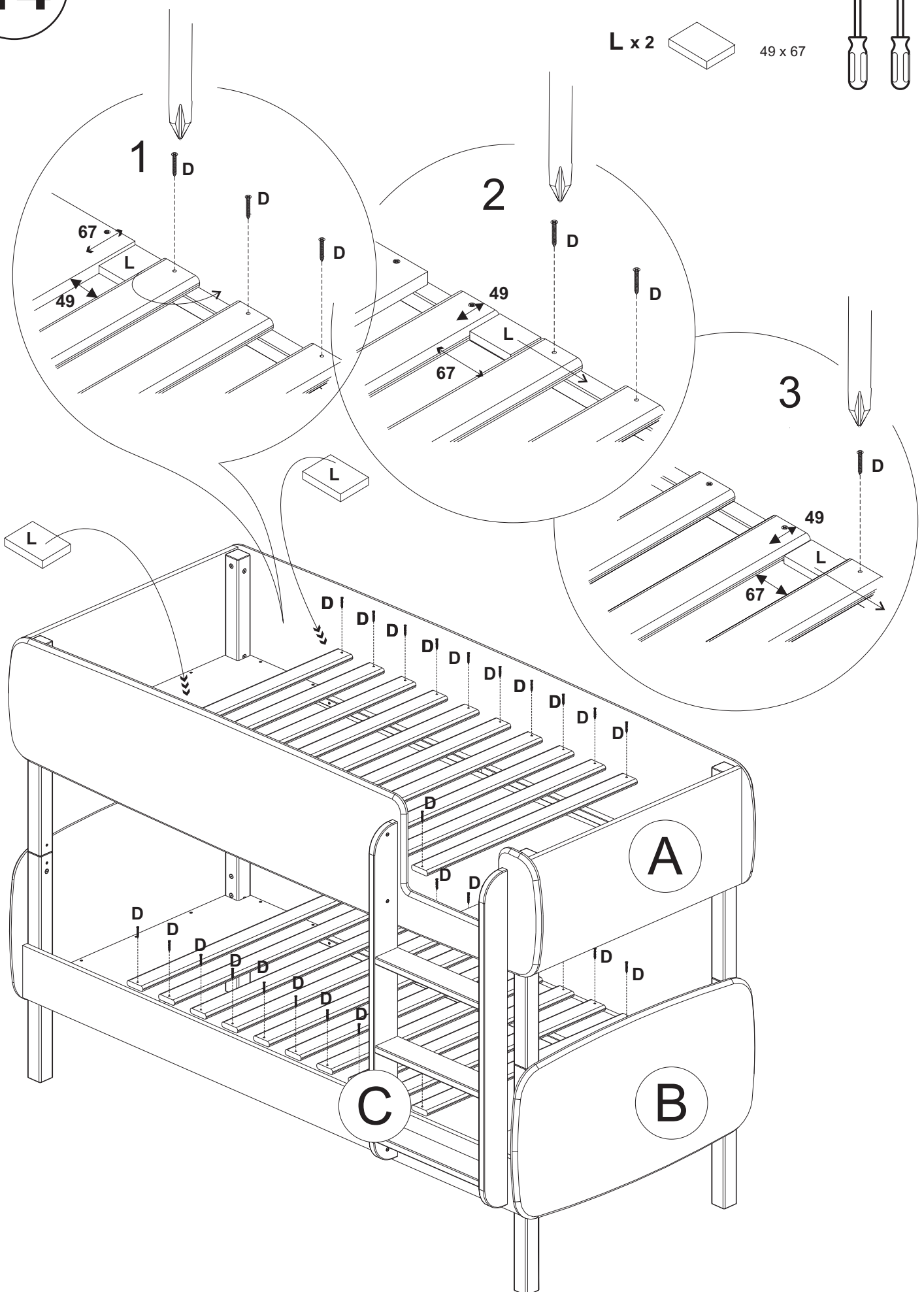
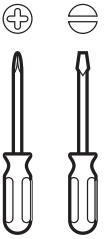

15

Option 2

D x 40



3.5x35

L x 2

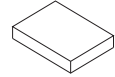

49 x 67

