

# NOTICE DE MONTAGE

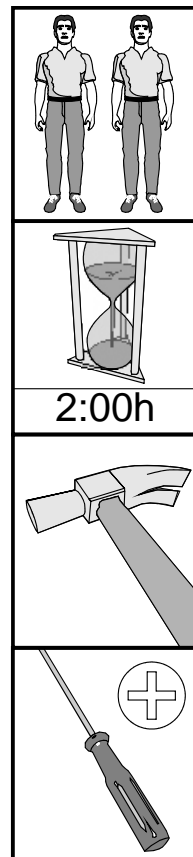

Stock Ref:854.2066

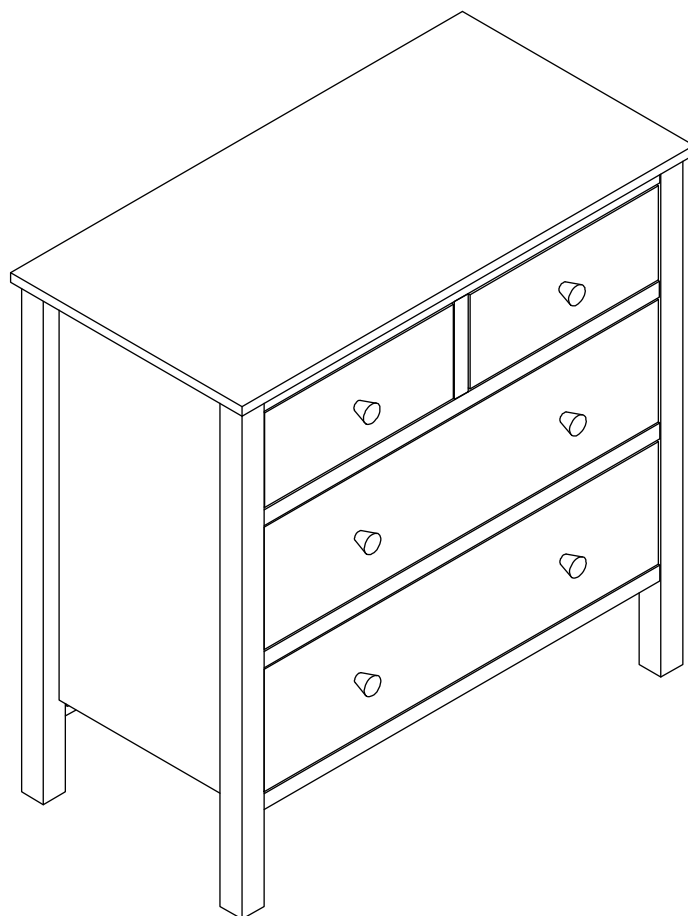

- De inhoud van uw pakket controleren alvorens de montage te beginnen
- De verpakking niet beschadigen, deze kan heel handig zijn om de onderdelen te beschermen tegen schokken en krassen tijdens de montage.
- Zet vervolgens het meubel in elkaar in de volgorde die is bepaald in de nummering.
- Neem bij problemen contact op met onze klantenservice.
- Laat na ontvangst uw meubels luchten (deuren en laden open) in een goed geventileerde ruimte. Zorg regelmatig voor frisse lucht in uw kamer



- Contrôlez le contenu de votre colis avant de procéder au montage.
- Ne détériorez pas l'emballage, il vous sera très utile pour protéger les éléments des coups ou rayures pendant le montage.
- Assemblez ensuite le meuble en suivant l'ordre défini par la numérotation.
- En cas de problème contactez notre Service Après-Vente.
- **A réception, aérer vos meubles, portes et tiroirs ouverts, dans une pièce bien ventilée. Renouveler régulièrement l'air de vos pièces.**









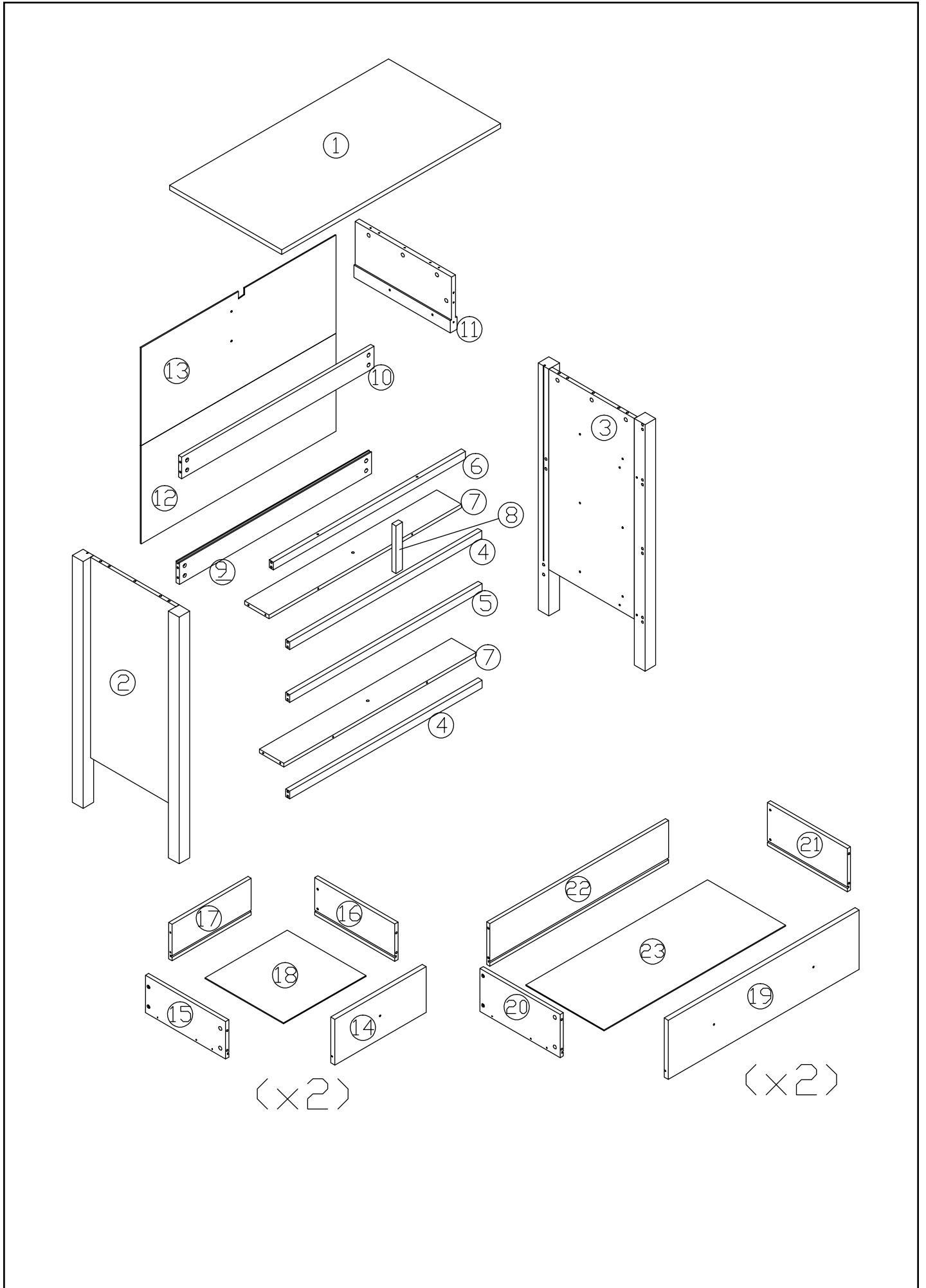

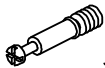







- Check the content of your parcel before assembling.
- Do not throw away the packing which could be very useful to protect the panels from knocks and scratches when assembling.
- Assemble the article following the order of the numbers indicated.
- Should any problems arise, please contact our After Sales Service.
- Upon receipt, place the furniture in a well-ventilated room and leave doors and drawers open to allow the air to circulate. Change the air in your rooms on a regular basis.

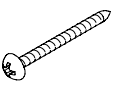

- Confira o conteúdo da sua encomenda antes de iniciar a montagem.
- Proceda à montagem do móvel seguindo a ordem definida pela numeração.
- Não danifique a embalagem, poderá ser-lhe útil para proteger os elementos de golpes ou riscos durante a montagem.
- Para qualquer esclarecimento, contacte os nossos serviços através do telefone.
- Quando da sua recepção, arejar os seus móveis, portas e gavetas abertos, numa divisão bem ventilada. Renovar regularmente o ar das suas divisões

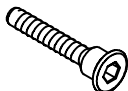

<p>ø6.5x20</p> <p>(A)  x46</p>	<p>ø12x10</p> <p>(B)  x46</p>	<p>ø6x30</p> <p>(C)  x22</p>	<p>M5.8x9</p> <p>(D)  x16</p>	<p>ø3x10</p> <p>(E)  x26</p>
<p>(F)  x4</p>	<p>(G)  x4</p>	<p>(H)  x4</p>	<p>(J)  x4</p>	<p>(K)  x6</p>
<p>M4x25</p> <p>(L)  x6</p>	<p>ø3.5x25</p> <p>(M)  x4</p>	<p>(N)  x8</p>	<p>ø3x14</p> <p>(P)  x8</p>	<p>(T)  x1</p>
<p>ø7x40</p> <p>(R)  x1</p>	<p>(Q)  x1</p>			

01

(x2)

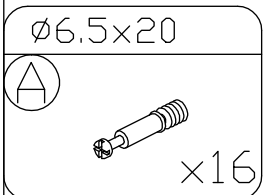
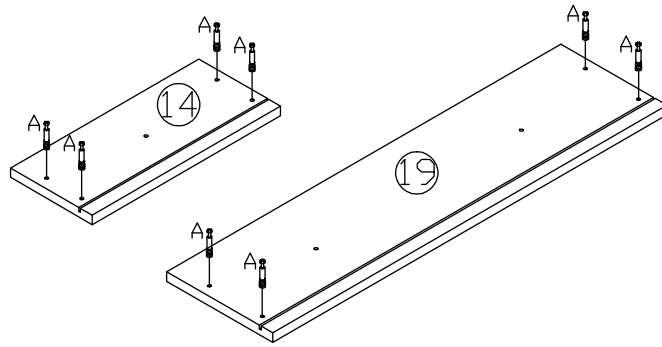

02

(x2)

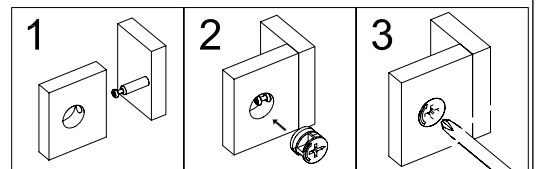
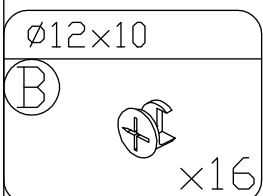
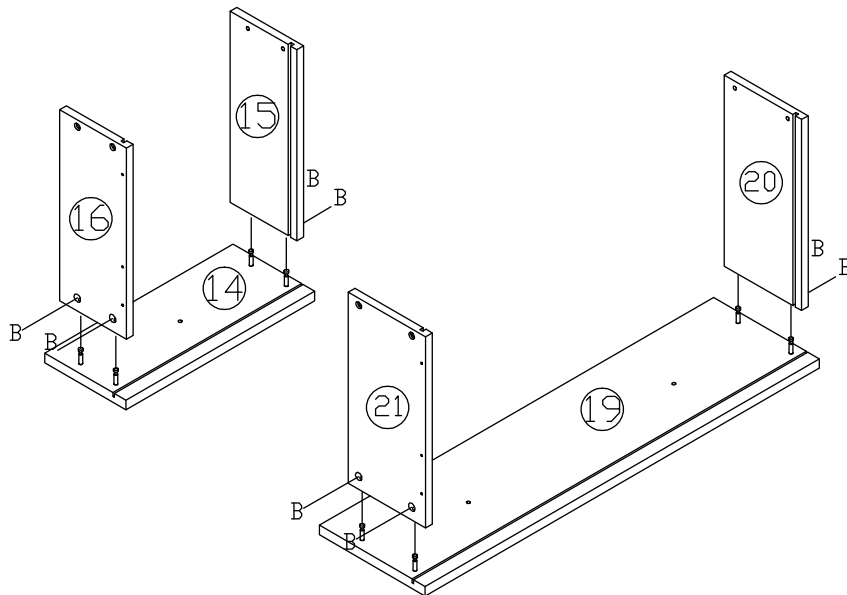

03

(x2)

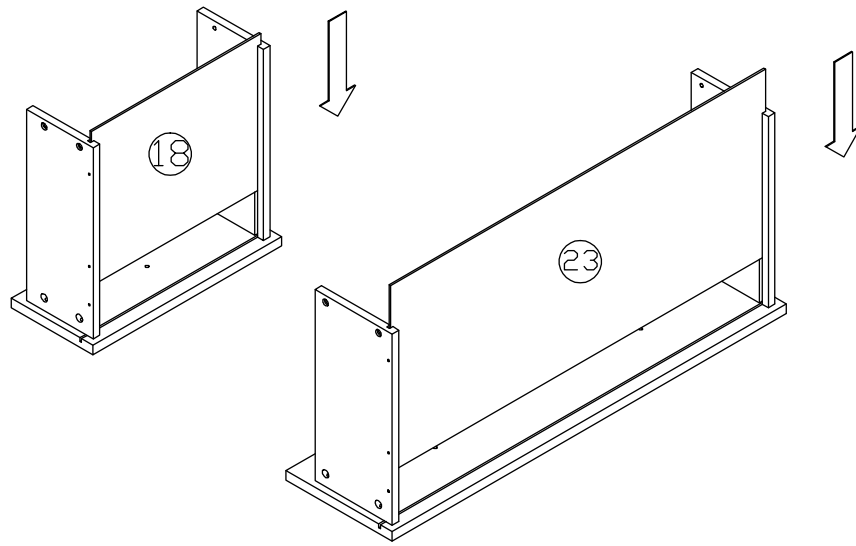

04

(x2)

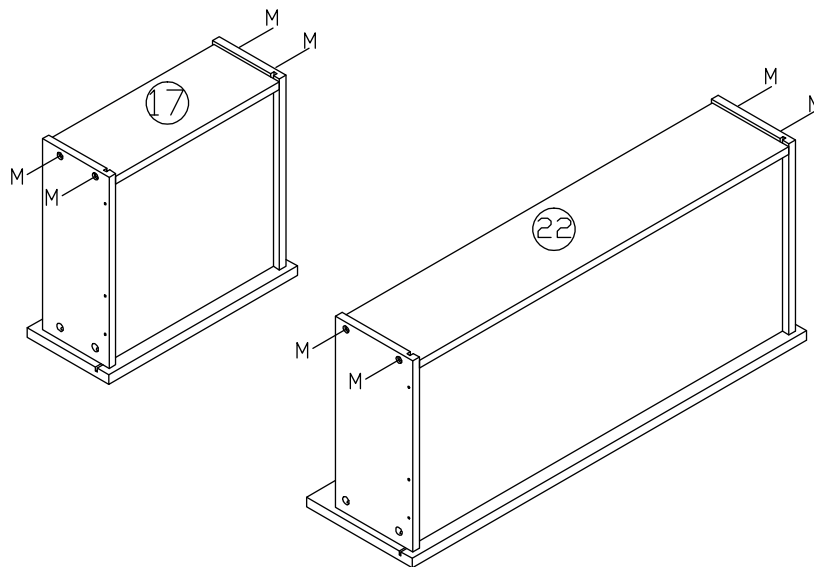

ø3.5x25

(M)

x16

05

(x2)

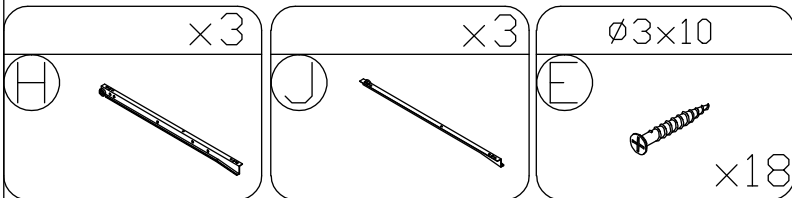
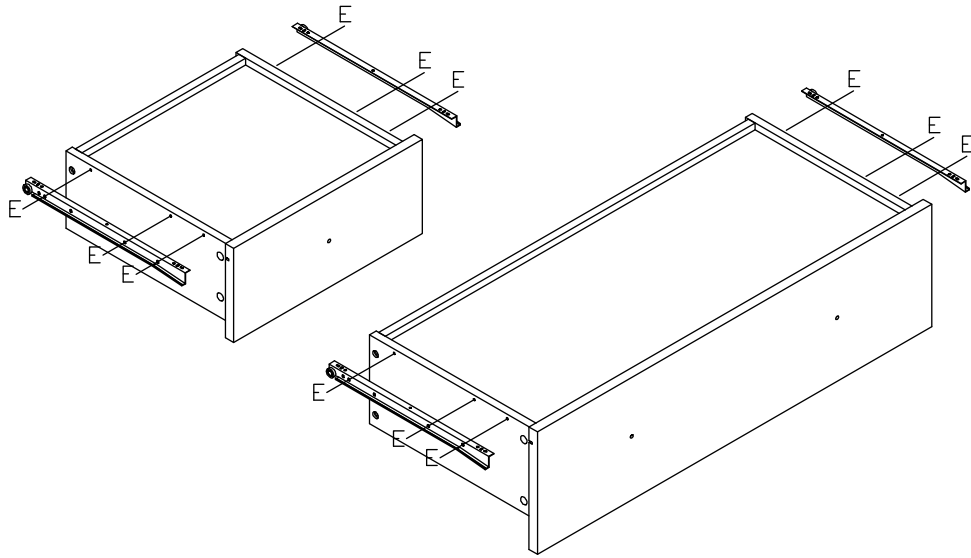

06

(x2)

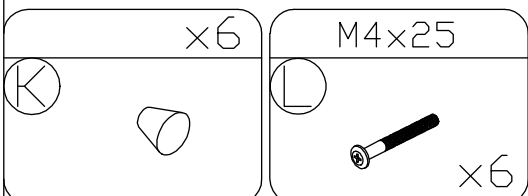
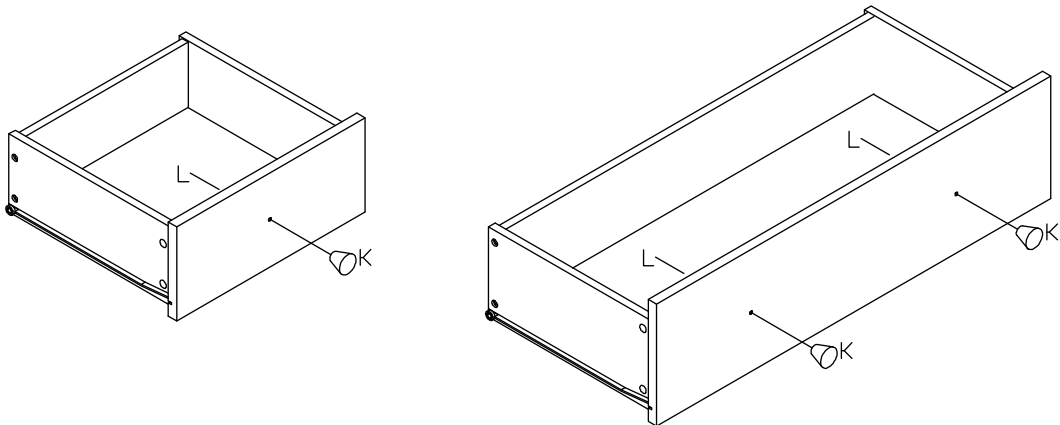

07

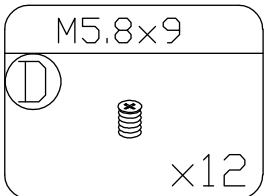
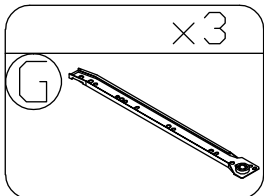
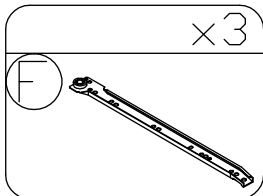
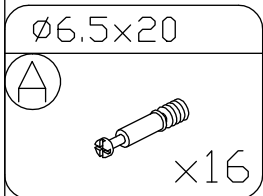
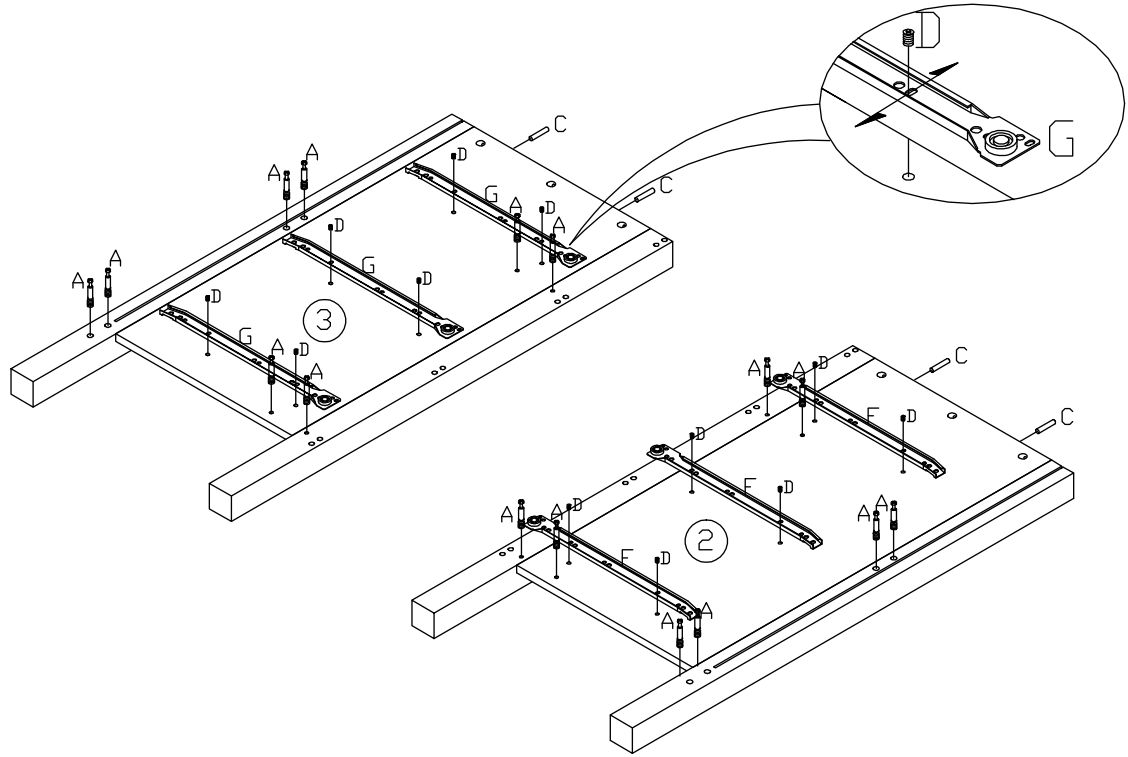

08

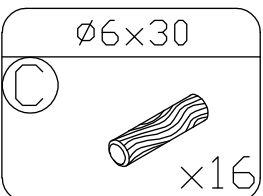
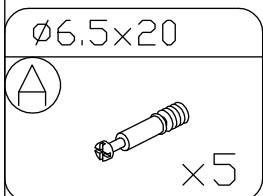
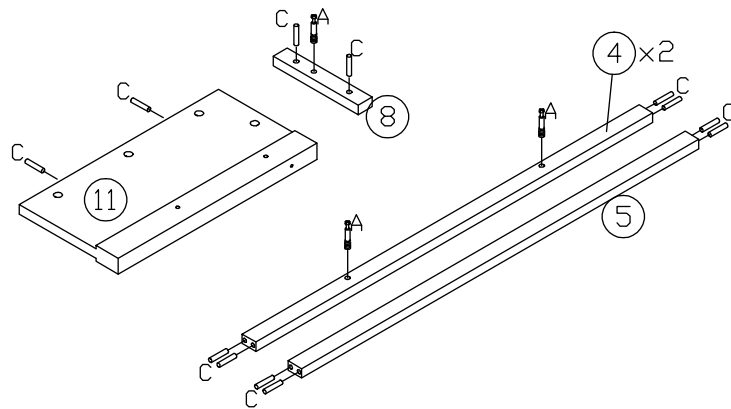

09

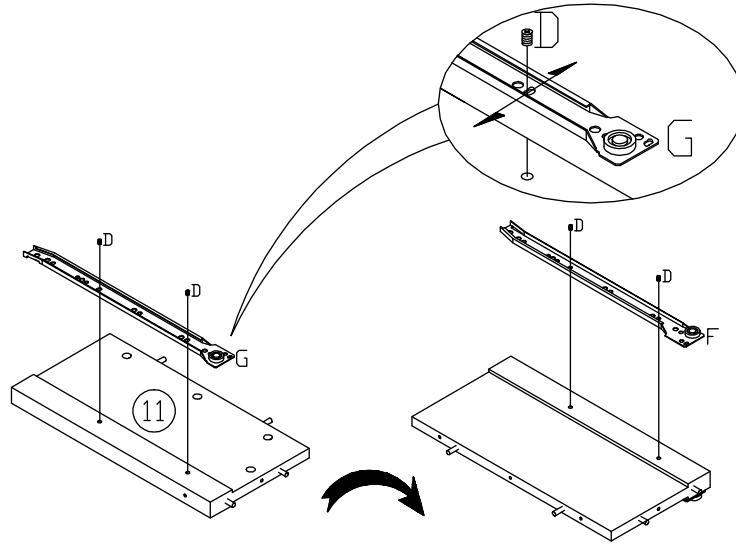

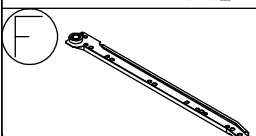
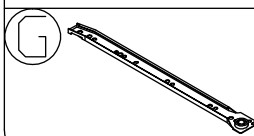
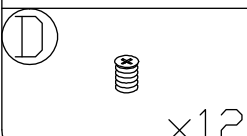
 ×1	 ×1	M5.8×9  ×12
---------------------------------------------------------------------------------------	---------------------------------------------------------------------------------------	--------------------------------------------------------------------------------------------------

10

(×2)

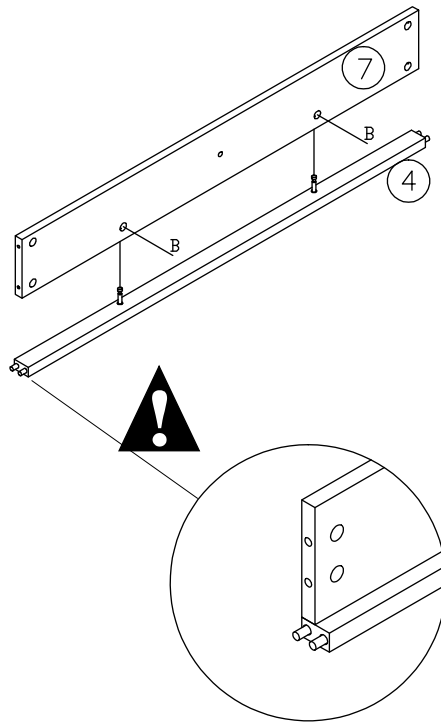

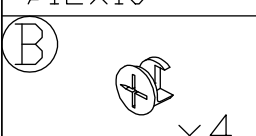
Ø12×10  ×4
--------------------------------------------------------------------------------------------------

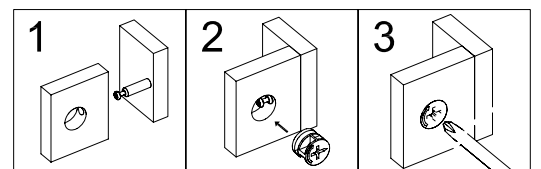



11

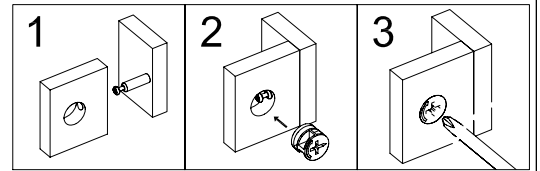
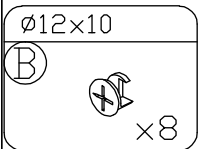
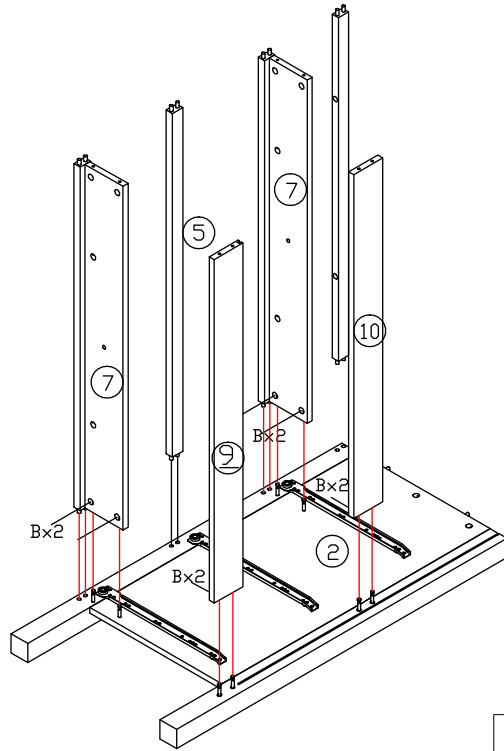

12

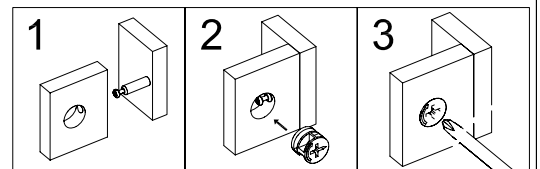
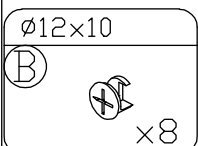
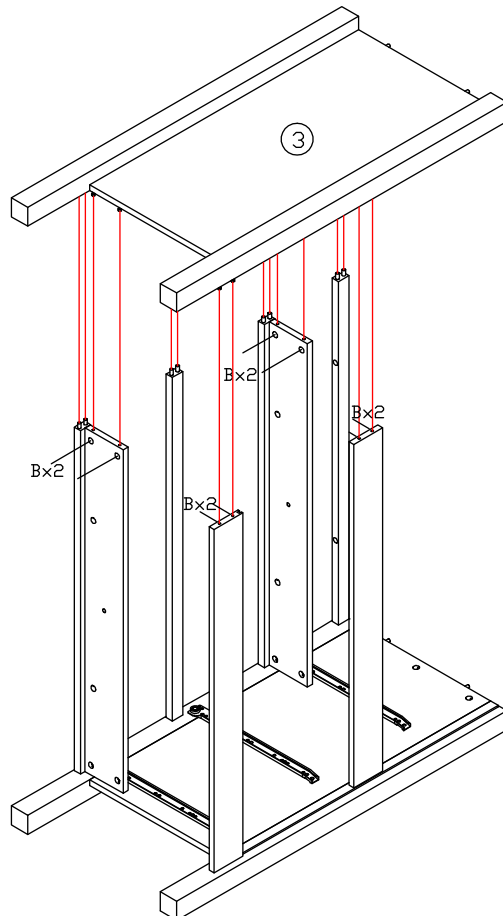

13

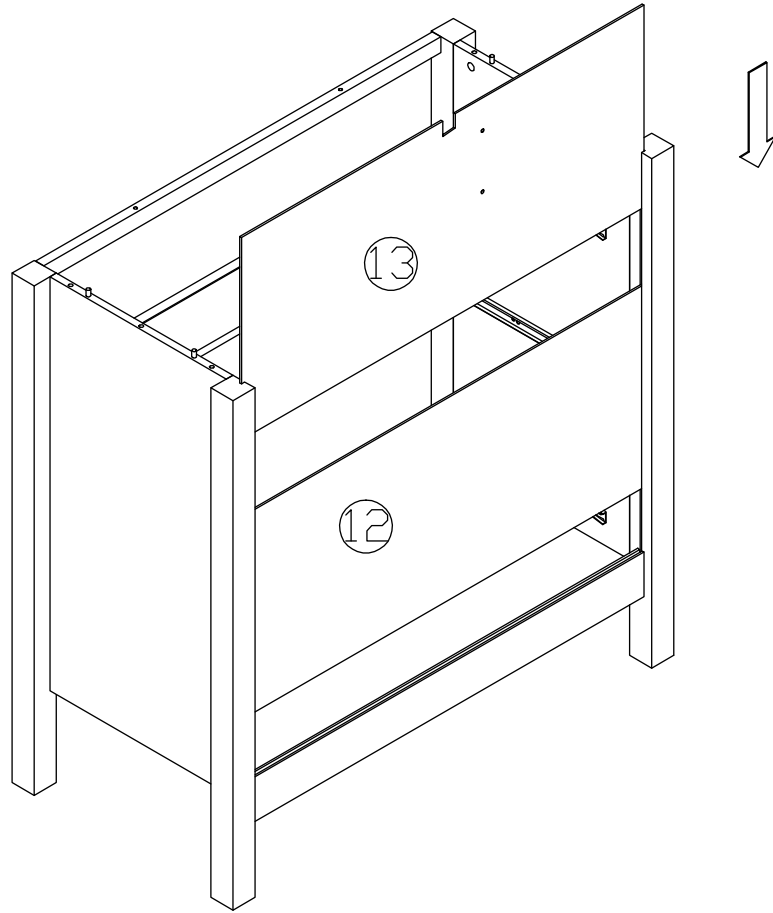

14

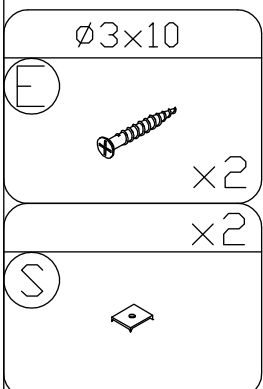
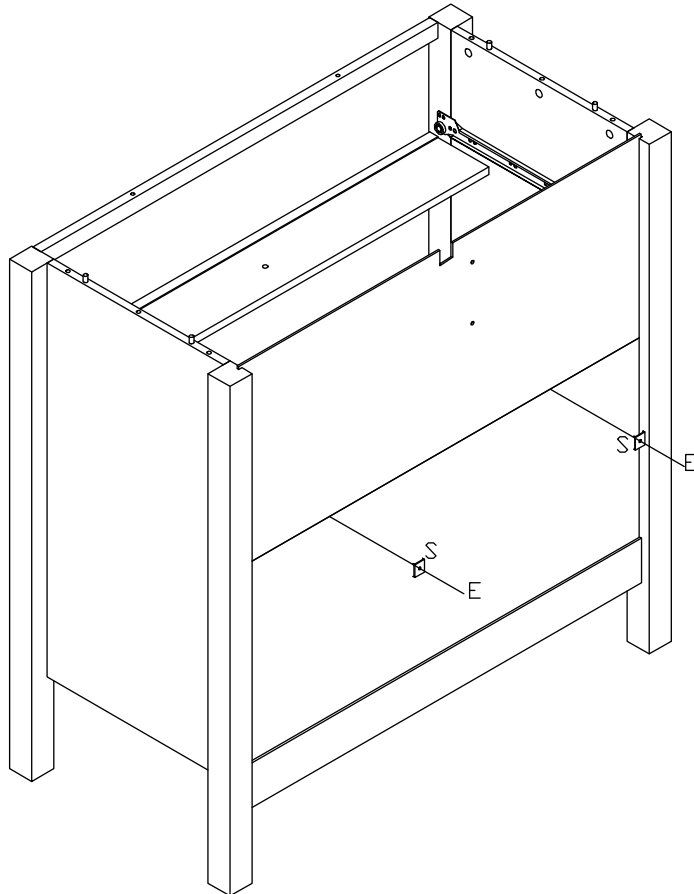

15

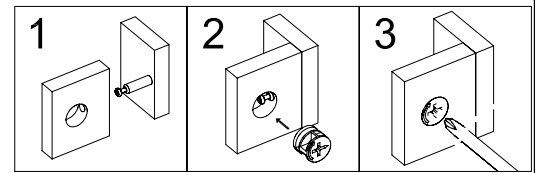
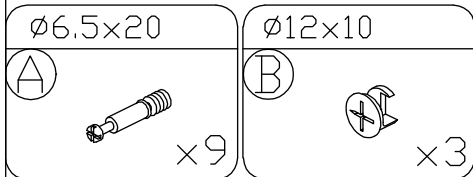
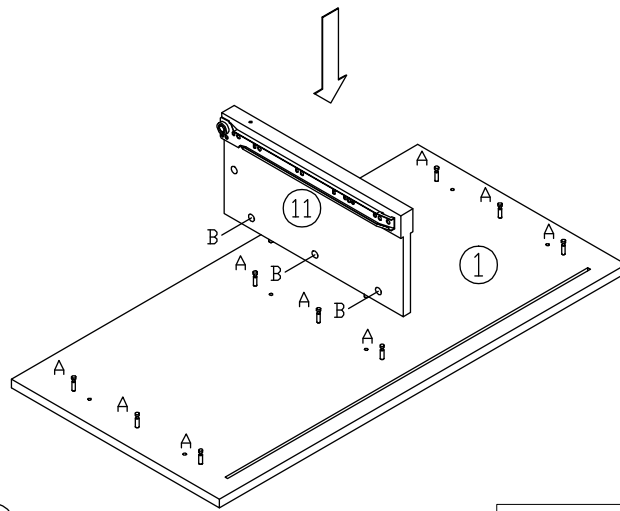

16

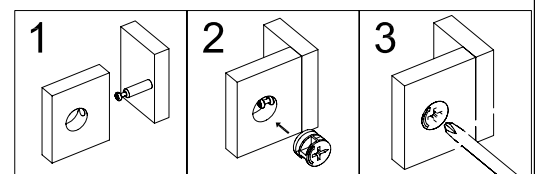
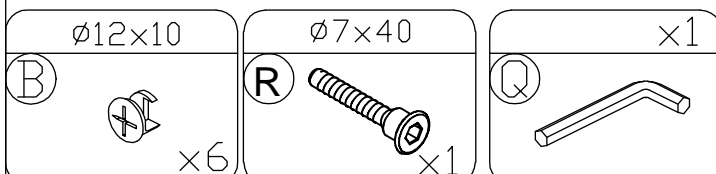
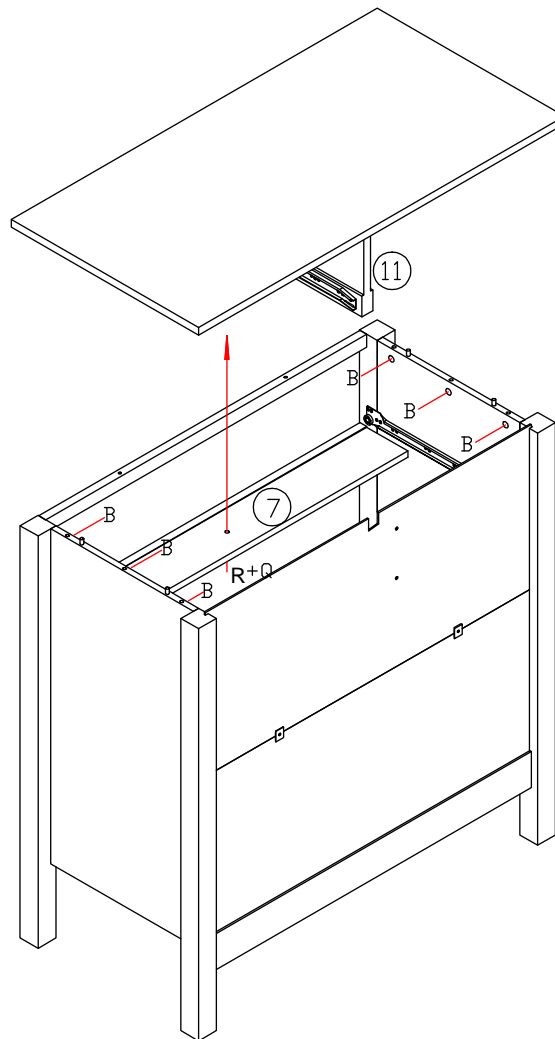

17

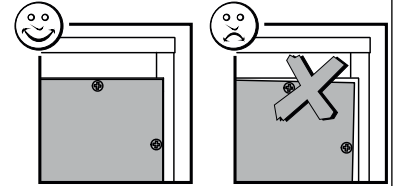
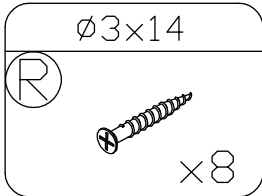
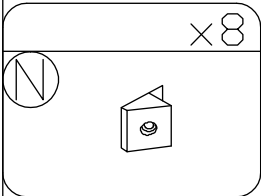
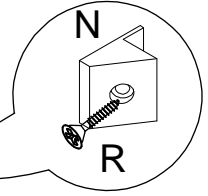
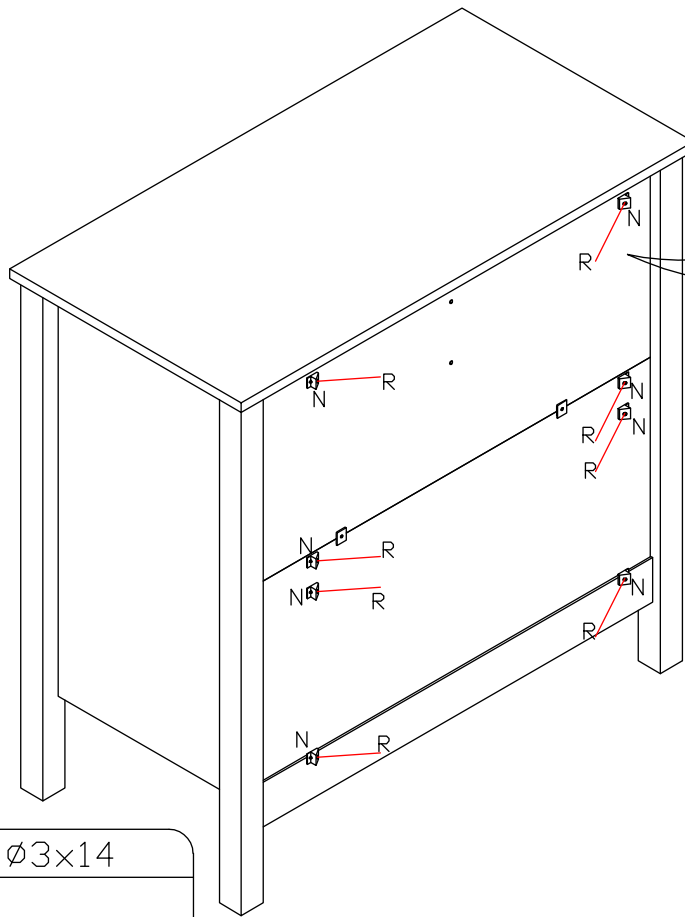

18

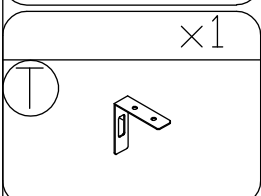
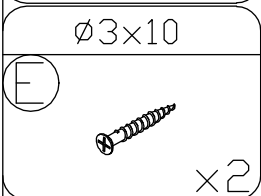
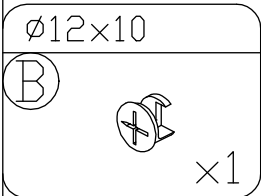
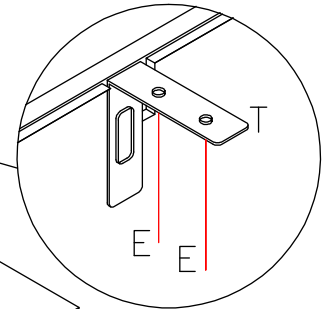
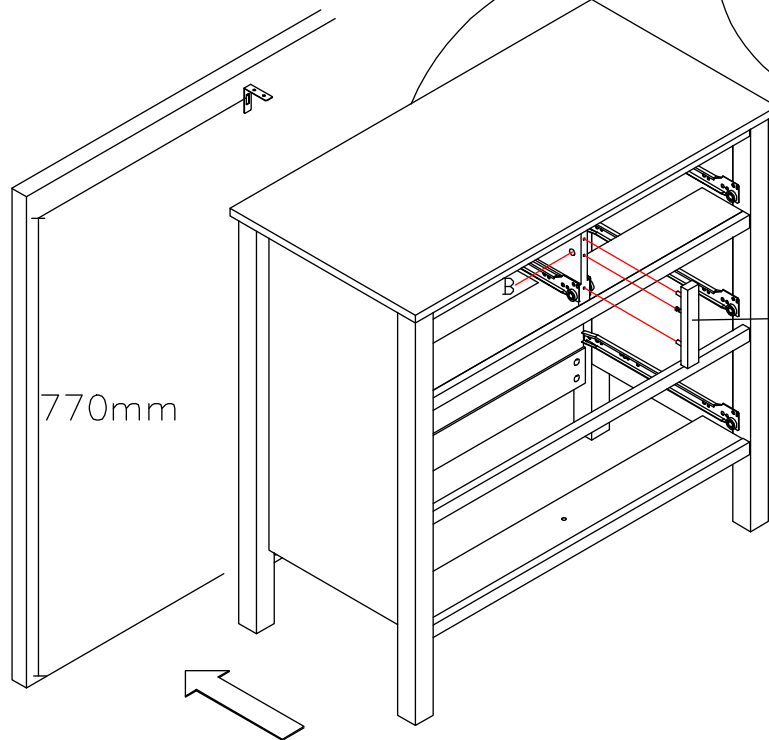

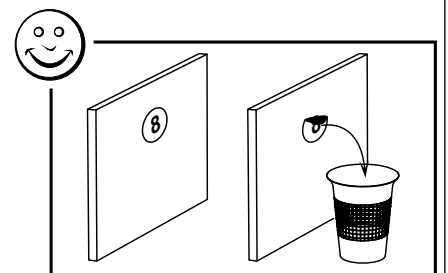
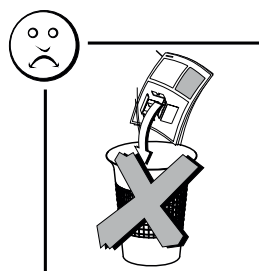
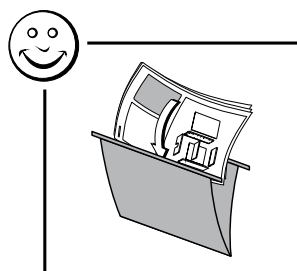
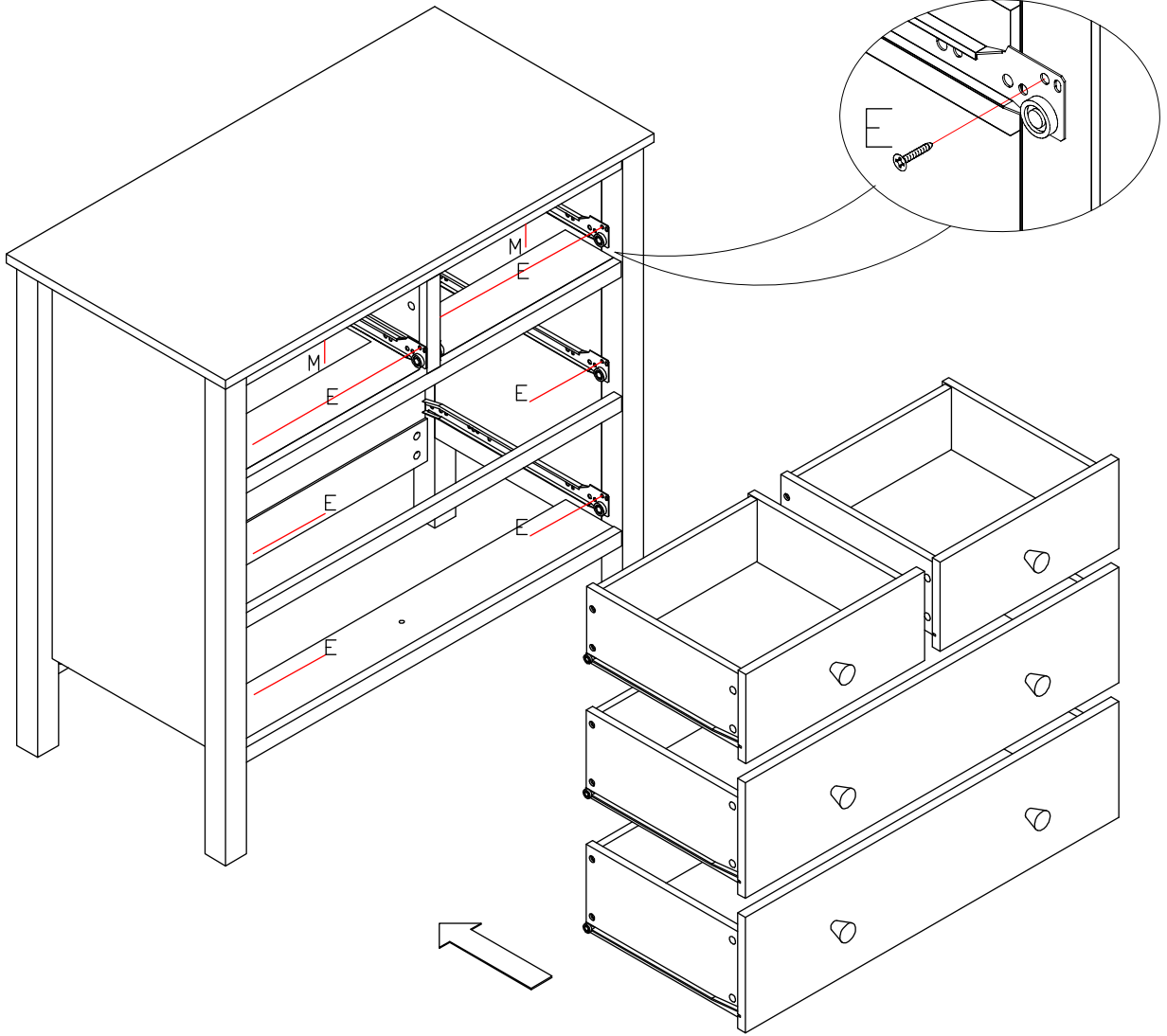
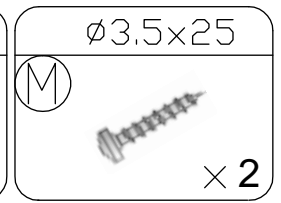
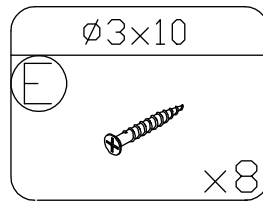

! !

Il existe une grande diversité de types de murs ou cloisons, c'est la raison pour laquelle nous ne pouvons vous fournir le type exact de fixation. Il est nécessaire d'identifier le type de paroi à laquelle vous allez fixer ce produit afin de vous procurer les fixations appropriées. Voici quelques exemples de fixations conseillées pour :

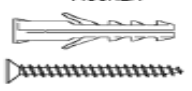
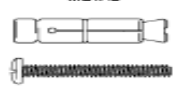
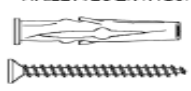
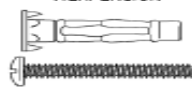
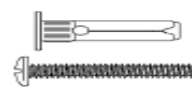
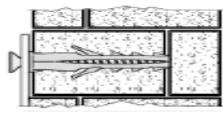
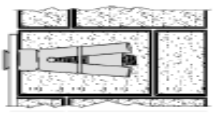
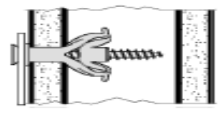
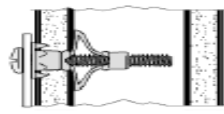
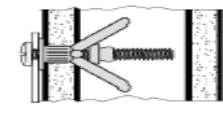
LES MURS PLEINS CHEVILLE NYLON "FISCHER"	CHEVILLE D'ANCRAGE MÉTAL	CHEVILLE D'ANCRAGE A AILETTES EN NYLON	LES CLOISONS CREUSES CHEVILLE MÉTALLIQUE A EXPANSION	CHEVILLE "MOLLY"
				
				



Utiliser une taille de forêt adaptée à la quincaillerie utilisée et au type de mur.

! !

Due to the wide diversity of wall or partition types, we cannot provide you with suitable attachment fixtures. To determine which attachment fixtures to use, you will need to identify the type of wall to which you will be fixing this product. Here are some examples of attachment fixtures recommended for:

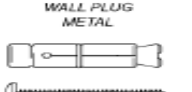
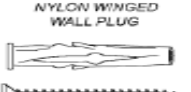
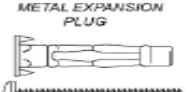
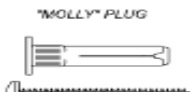
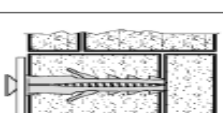
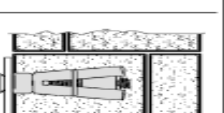
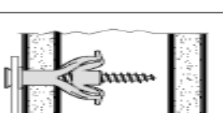
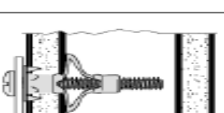
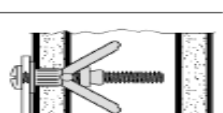

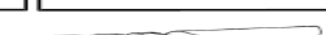





BLIND WALLS NYLON PLUG "FISCHER"	WALL PLUG METAL	NYLON WINGED WALL PLUG	STUDDED WALLS METAL EXPANSION PLUG	"MOLLY" PLUG
				
				

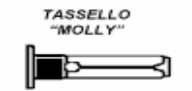
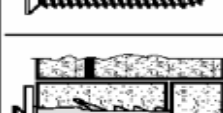

Use a drill bit that is compatible in size with the hardware used and the type of wall.

! !

Esiste una gran varietà di tipi di muri o paratie e noi siamo in grado di fornirvi il tipo esatto di fissaggio per ognuno di essi. E' necessario identificare il tipo di parete alla quale intendete fissare questo prodotto in modo da fornirvi i fissaggi più idonei. Ecco qualche esempio di fissaggi consigliati per :







I MURI PIENI TASSELLO NYLON "FISCHER"	TASSELLO DI ANCORAGGIO IN METALLO	TASSELLO DI ANCORAGGIO AD ALETTE IN NYLON	PARATIE CAVE TASSELLO METALLICO AD ESPANSIONE	TASSELLO "MOLLY"
				
				

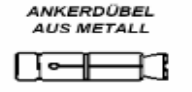

Utilizzare una punta di trapano adatta agli utensili utilizzati e al tipo di muro.

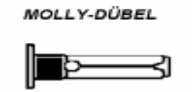
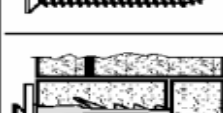
! !

Es gibt eine Vielzahl verschiedener Arten von Mauern oder Zwischenwänden, und aus diesem Grunde können wir Ihnen den genau entsprechenden Befestigungstyp nicht bereitstellen. Zunächst ist es erforderlich, die exakte Bauart der Wand zu ermitteln, an der Sie dieses Produkt anbringen werden, um die für diese Wand geeigneten Befestigungsmittel im Fachhandel erwerben zu können. Nachfolgend einige Beispiele empfohlener Befestigungen für:

VOLLWÄNDE NYLONDÜBEL "FISCHER"	ANKERDÜBEL AUS METALL	ANKERDÜBEL MIT NYLONFLÜGELN	HOHLWÄNDE SPREIZDÜBEL FÜR VERANKERUNG AUS METALL	MOLLY-DÜBEL
				
				

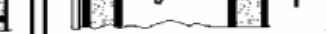

Bitte verwenden Sie eine für die Eisenwaren und den Wandtyp geeignete Bohrergröße.