

5617588

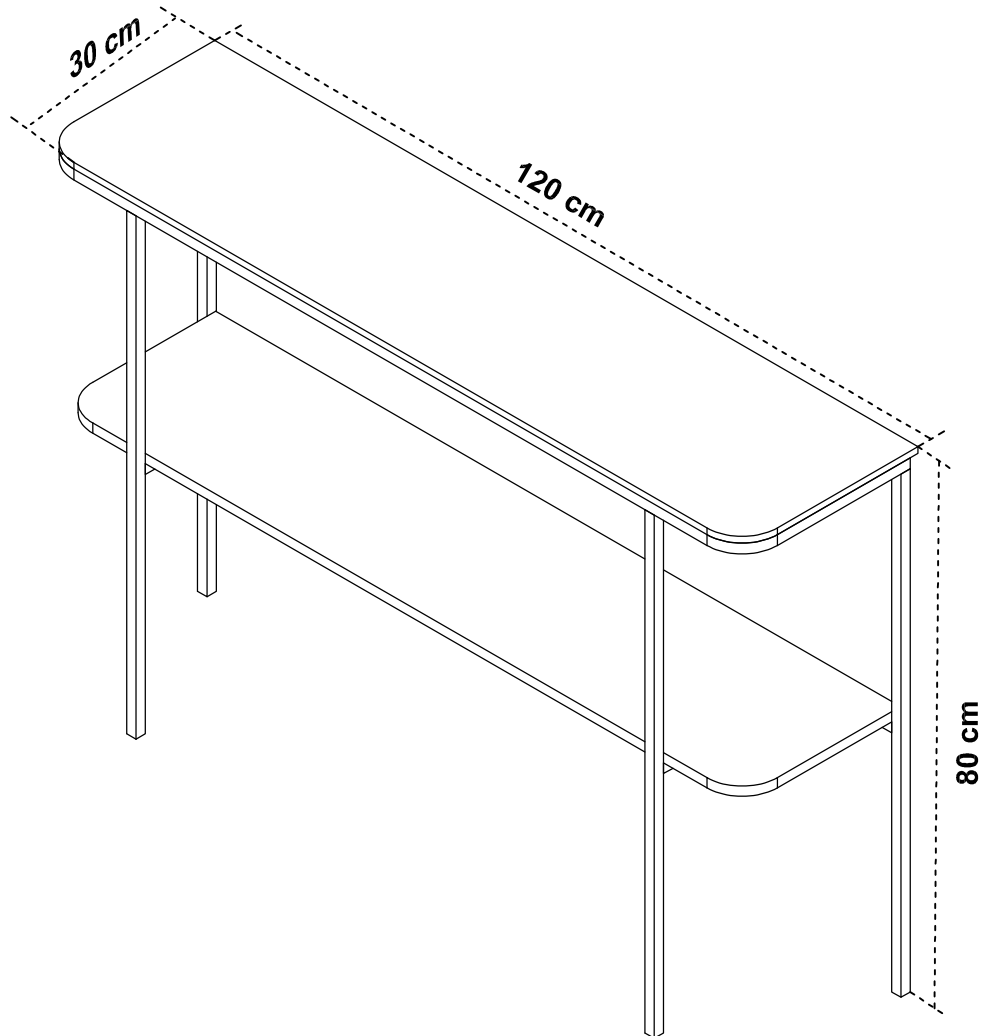



- Contrôlez le contenu de votre colis avant de procéder au montage.
- Ne défilez pas l'emballage, il vous sera très utile pour protéger les éléments des coups ou rayures pendant le montage.
- Assemblez ensuite le meuble en suivant l'ordre défini par la numérotation.
- En cas de problème contactez notre Service Après-Vente.
- A réception, aérer vos meubles, portes et tiroirs ouverts, dans une pièce bien ventilée. Renouveler régulièrement l'air de vos pièces.

- Check the content of your parcel before assembling.
- Do not throw away the packing which could be very useful to protect the panels from knocks and scratches when assembling.
- Assemble the article following the order of the numbers indicated.
- Should any problems arise, please contact our After Sale Service.
- Upon receipt, place the furniture in a well-ventilated room and leave doors and drawers open to allow the air to circulate. Change the air in your rooms on a regular basis.

- Confira o conteúdo da sua encomenda antes de iniciar a montagem.
- Proceda à montagem do móvel seguindo a ordem definida pela numeração.
- Não danifique a embalagem, poderá ser-lhe útil para proteger os elementos de golpes ou riscos durante a montagem.
- Para qualquer esclarecimento, contacte os nossos serviços através do telefone.
- Aquando da sua recepção, arejar os seus móveis, portas e gavetas abertos, numa divisão bem ventilada. Renovar regularmente o ar das suas divisões.

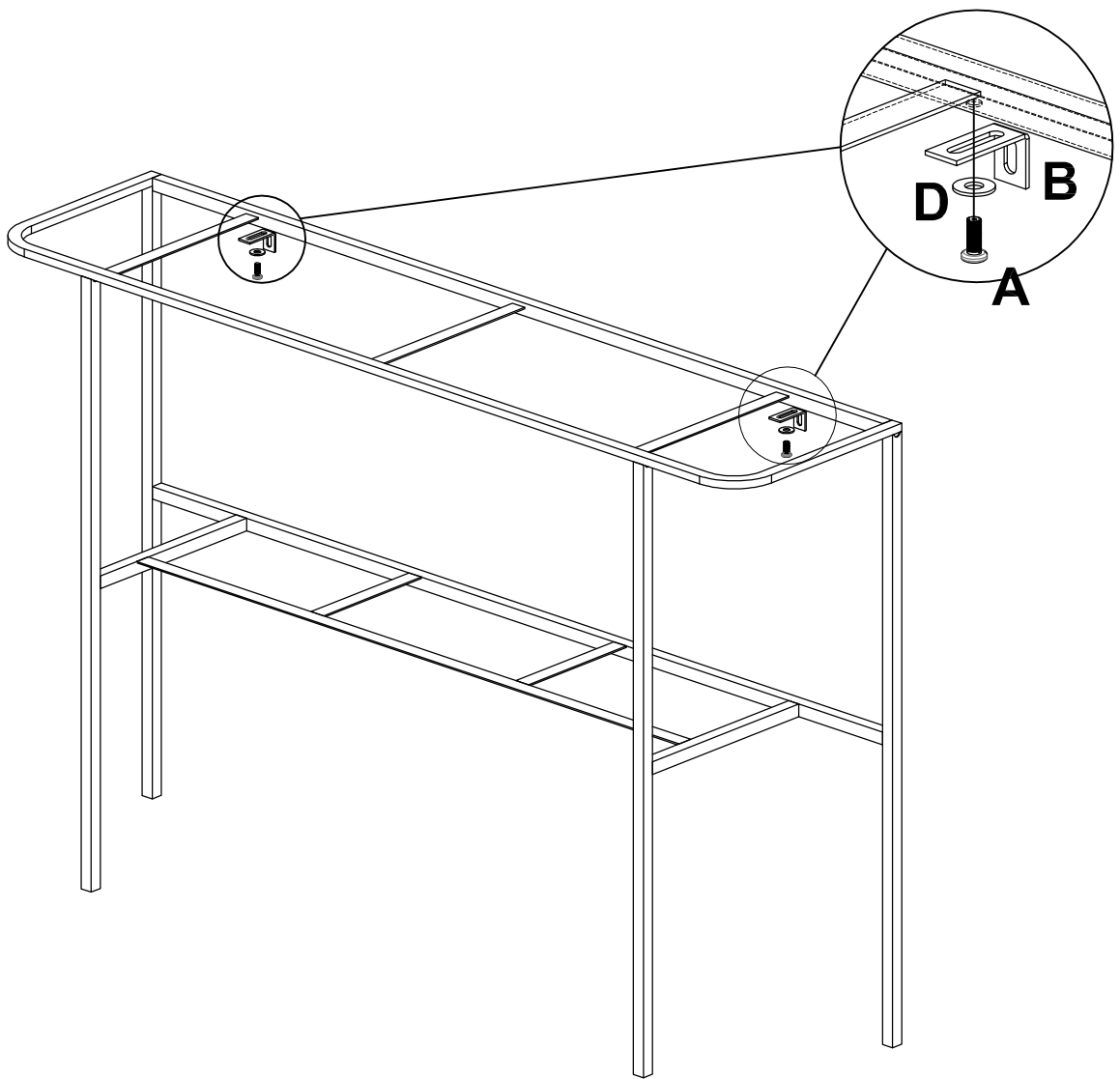
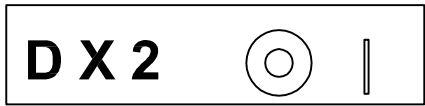
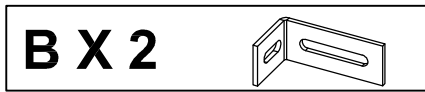
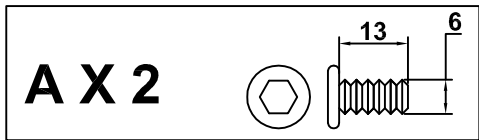
- De Inhoud van uw pakket controleren alvorens met de montage te beginnen
- De Verpakking niet beschadigen, deze kan heel handig zijn om de onderdelen te beschermen tegen schokken en krassen tijdens de montage.
- Zet vervolgens het meubel in elkaar in de volgorde die is bepaald in de nummering
- Neem bij problemen contact op met onze klantenservice.
- Laat na ontvangst uw meubels luchten (deuren en laden open) in een goed geventileerde ruimte. Zorg regelmatig voor frisse lucht in uw kamer



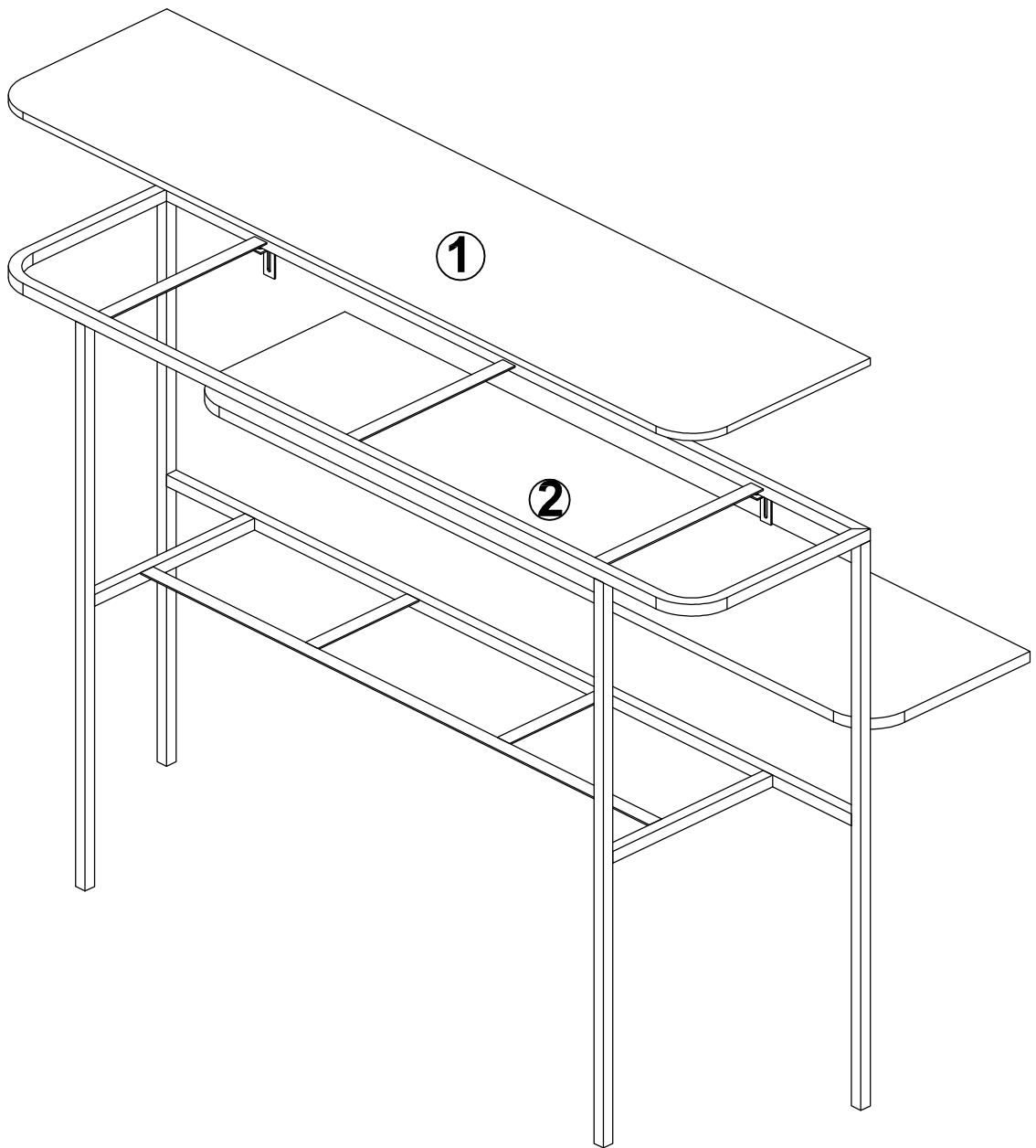

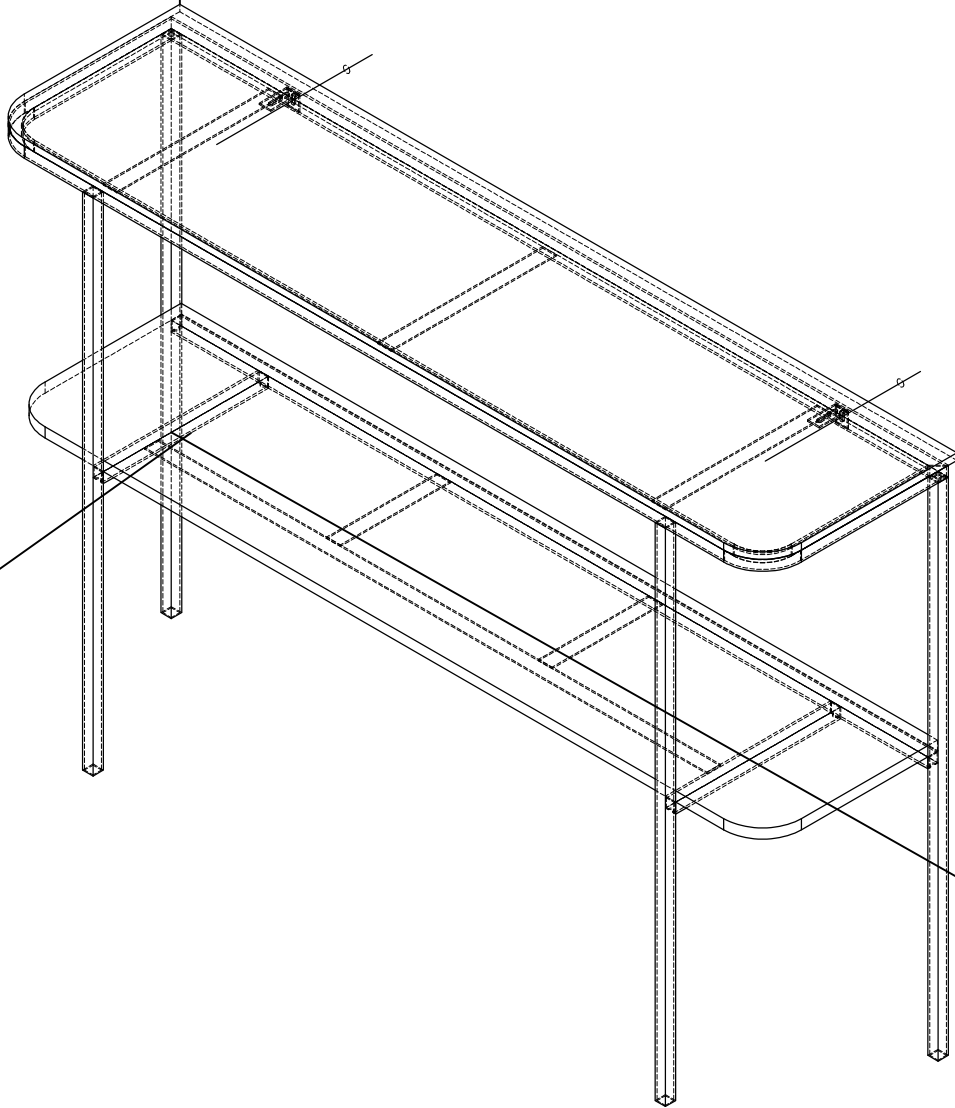

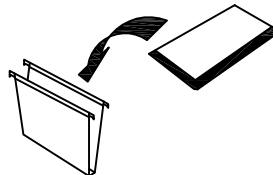
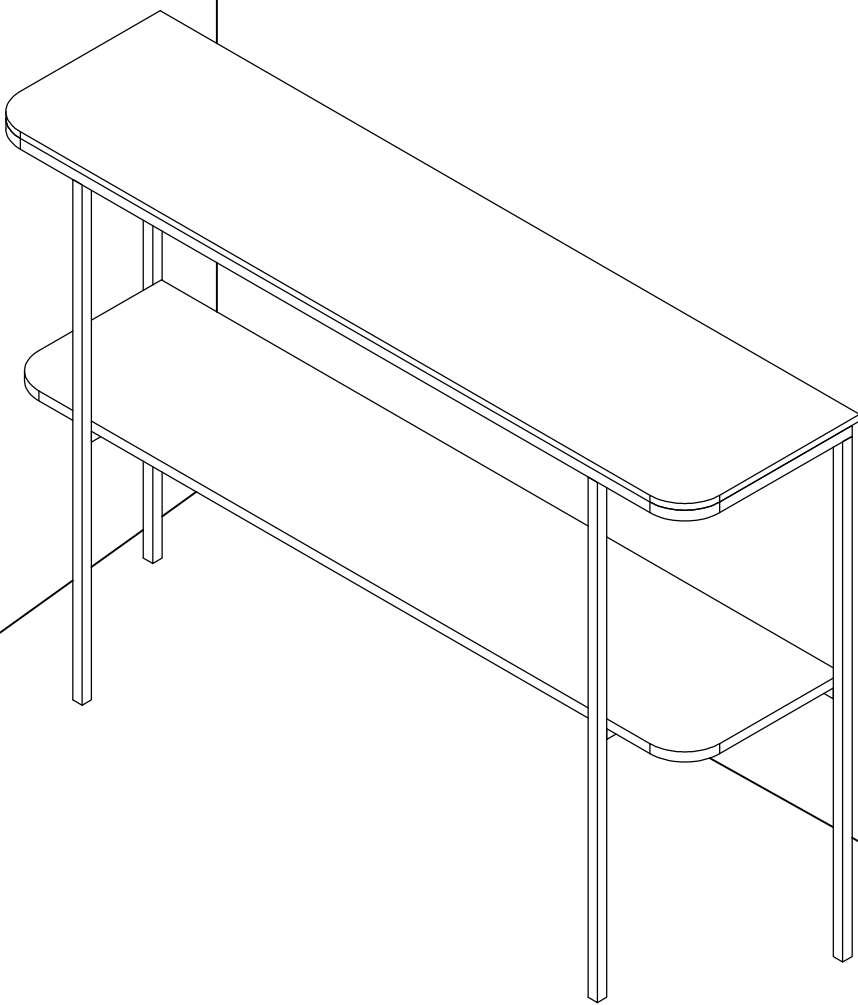

Préconisations d'utilisation pour plateau MARBRE

Le marbre est un matériau naturellement poreux qui nécessite une protection.

Il doit avoir été préalablement protégé par une couche de cire siliconée pour prévenir du risque de pénétration de liquides.

A noter que les liquides gras pénètrent plus rapidement dans le matériau que les liquides à base d'eau.

C'est aussi un matériau sensible à la chaleur dont le risque est le fendillement.

IMPORTANT

Tout liquide renversé doit être immédiatement essuyé avec un chiffon blanc qui aura été au préalable trempé dans de l'eau tiède et essoré.

Utiliser des dessous de verres et repose-plats pour protéger la surface de la table de la chaleur.

Ne pas utiliser de produits acides ou alcalins qui peuvent endommager la surface de la table.

Conseils d'entretien :

Pour l'entretien régulier, utiliser simplement un chiffon doux et humide.

Enlevez la poussière et la saleté avec un produit ménager neutre

Ne pas utiliser de nettoyeurs à base de vinaigre



Il existe une grande diversité de types de murs ou cloisons, c'est la raison pour laquelle nous ne pouvons vous fournir le type exact de fixation. Il est nécessaire d'identifier le type de paroi à laquelle vous allez fixer ce produit afin de vous procurer les fixations appropriées. Voici quelques exemples de fixations conseillées pour :



LES MURS PLEINS

**CHEVILLE NYLON
"FISCHER"**

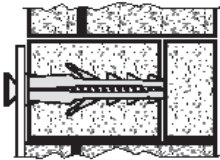
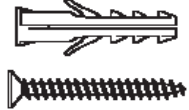

**CHEVILLE D'ANCRAGE
MÉTAL**

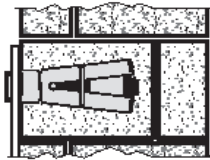
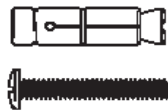

**CHEVILLE D'ANCRAGE
A AILETTES EN NYLON**

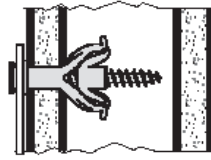
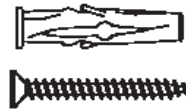

LES CLOISONS CREUSES

**CHEVILLE MÉTALLIQUE
A EXPENSION**

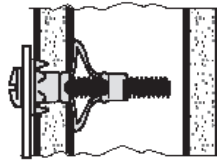

CHEVILLE "MOLLY"

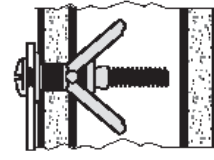
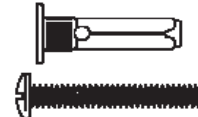

Utiliser une taille de forêt adaptée à la quincaillerie utilisée et au type de mur.



Due to the wide diversity of wall or partition types, we cannot provide you with suitable attachment fixtures. To determine which attachment fixtures to use, you will need to identify the type of wall to which you will be fixing this product. Here are some examples of attachment fixtures recommended for:



BLIND WALLS

**"FISCHER"
Nylon plug**

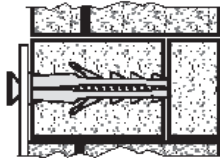
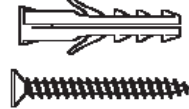

**Metal
Wall plug**

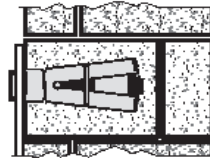
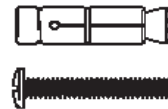

**Nylon winged
Wall plug**

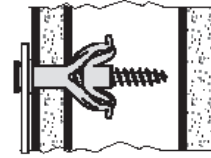
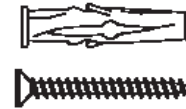

STUDDED WALLS

**Metal expansion
plug**

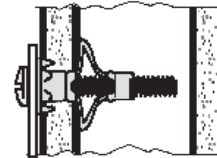

"MOLLY" plug

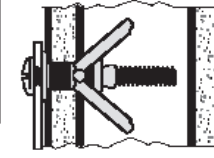
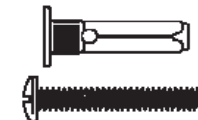

Use a drill bit that is compatible in size with the hardware used and the type of wall.



Esiste una gran varietà di tipi di muri o paratie e noi siamo in grado di fornirvi il tipo esatto di fissaggio per ognuno di essi. E' necessario identificare il tipo di parete alla quale intendete fissare questo prodotto in modo da fornirvi i fissaggi più idonei. Ecco qualche esempio di fissaggi consigliati per :



I MURI PIENI

**TASSELLO NYLON
"FISCHER"**

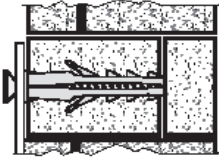
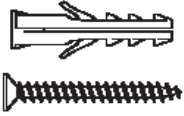

**TASSELLO DI
ANCORAGGIO IN
METALLO**

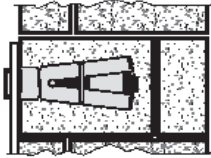
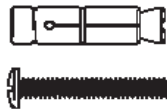

**TASSELLO DI
ANCORAGGIO AD
ALETTE IN NYLON**

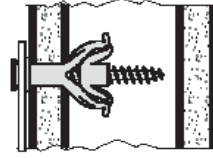

**PARATIE CAVE
TASSELLO METALLICO
AD ESPANSIONE**

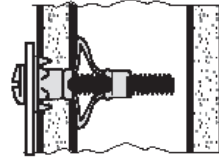

**TASSELLO
"MOLLY"**

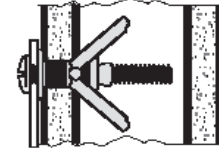
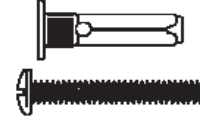

Utilizzare una punta di trapano adatta agli utensili utilizzati e al tipo di muro.



Es gibt eine Vielzahl verschiedener Arten von Mauern oder Zwischenwänden, und aus diesem Grunde können wir Ihnen den genau entsprechenden Befestigungstyp nicht bereitstellen. Zunächst ist es erforderlich, die exakte Bauart der Wand zu ermitteln, an der Sie dieses Produkt anbringen werden, um die für diese Wand geeigneten Befestigungsmittel im Fachhandel erwerben zu können. Nachfolgend einige Beispiele empfohlener Befestigungen für:



VOLLWÄNDE

**NYLONDÜBEL
„FISCHER“**

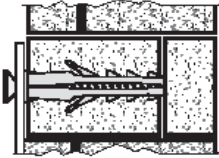
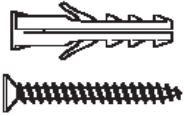

**ANKERDÜBEL
AUS METALL**

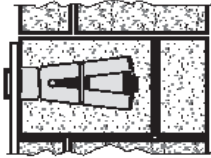
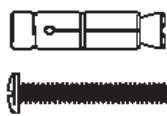

**ANKERDÜBEL MIT
NYLONFLÜGELN**

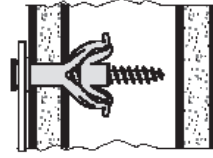
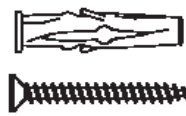

**HOHLWÄNDE
SPREIZDÜBEL FÜR
VERANKERUNG AUS METALL**

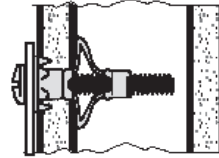

MOLLY-DÜBEL

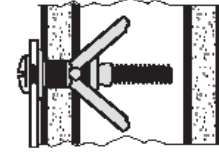
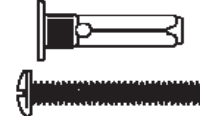

Bitte verwenden Sie eine für die Eisenwaren und den Wandtyp geeignete Bohrergröße.